



## Tachometer Transducers

AI-Tek tachometer transducers are self-generating units when used with speed sensors. They are designed primarily to provide an easy means of attaching a pulse generating assembly to rotating shafts. Sensor gapping, shaft run-out and mounting problems are eliminated. This makes the unit especially useful for shafts with high run-out. The ordering map on the following page provides information for selecting a unit for your particular application. Please note that sensors and cable assemblies must be ordered separately.

### Taper-Lock® Type

The assembly consists of a Taper-Lock bushing which enables quick attachment to rotating shafts. The transducer employs a rotor with small perforations along its periphery; a permanently lubricated sealed bearing; an outer ring and a reference rod which, when clamped in position, prevents the outer ring assembly from moving. The outer ring can accommodate up to three speed sensors for use in monitoring directions of rotation and speed.

### Sleeve Type

The AI-Tek sleeve-type transducer assembly is identical to the Taper-Lock type except that it provides a sleeve bushing with two set screws for installation purposes, allowing larger shaft sizes.

## Mechanical Specifications

*Lubrication:* Bearings are permanently lubricated; do not use pressure washes or solvents.

*Finish:* Reference rod and outer ring are anodized aluminum.

*Reference Rod:* 1/4" diameter, 6" long

*Bearing Limits:* 4000 RPM max. speed

*Weight:* 54 oz. (1.53 kg) max.

*Sensor Mounting:* 5/8-18 UNF-2A threaded hole std.

## Electrical Specifications

*Output Frequency:* 30 pulses/rev. (1 Hz = 2RPM), Standard; 60 pulses/rev. (1 Hz = 1RPM), Optional.

*Output Voltage:* Depends on magnetic sensor used. One turn of sensor controls 0.056 inches of air gap based on 5/8-18 UNF-2A thread. Normal gap setting range from 0.005 to 0.020 inches.

*Ambient Temperature:* -30°C to +50°C

**NOTE:** *Not for use in abrasive atmospheres.*

*It is the customer's responsibility to determine whether the product is proper for customer's use and application.*

## Ease of Installation

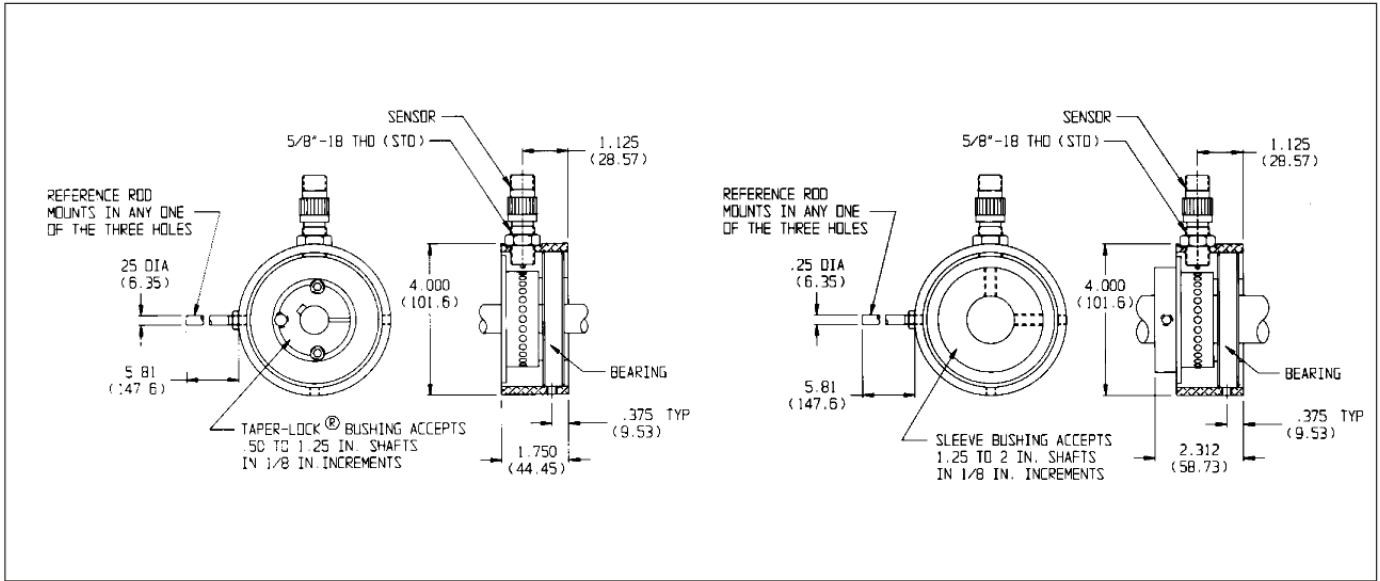

## Ordering Map

**T79850-103-**

- Basic Model**
1. Tachometer Transducer to accommodate one sensor, 30 pulses/rev. (standard)
  2. Tachometer Transducer to accommodate two sensors, 30 pulses/rev.
  4. Tachometer Transducer to accommodate one sensor, 60 pulses/rev.
  5. Tachometer Transducer to accommodate two sensors, 60 pulses/rev.

- Bearing/Bushing Type**
2. Taper-Lock bushing & sealed bearing

or

4. Sleeve bushing & sealed bearing

- Bore Size**
- 11 - Bore Diameter 1/2"
  - 12 - Bore Diameter 5/8"
  - 13 - Bore Diameter 3/4"
  - 14 - Bore Diameter 7/8"
  - 15 - Bore Diameter 1"
  - 16 - Bore Diameter 1 1/8"
  - 17 - Bore Diameter 1 1/4"

or

- 18 - Bore Diameter 1 3/8"
- 19 - Bore Diameter 1 1/2"
- 20 - Bore Diameter 1 5/8"
- 21 - Bore Diameter 1 3/4"
- 22 - Bore Diameter 1 7/8"
- 23 - Bore Diameter 2"

**Notes:**  
Standard mounting thread is 5/8-18 UNF-2A.

## Ordering Procedure

**Example:** Speed indicating system for a variable speed motor, 0 - 1750 RPM, 1" shaft diameter, panel-mount display within 10 ft., min. motor speed is 175 RPM.

1. Select Model No. **T79850 - 103 - 1215**  
30 PPR, std. basic model      
Taper-lock, sealed bearing  1" bore dia.

2. Select a speed sensor such as P/N 70085-1010-001
3. Select a cable assembly, P/N CA79860-01-00, to complement (2).
4. Select tachometer to meet application needs.

**Dimensions in inches and (mm).**