



## TACHTROL® 3 Dual Input Digital Tachometer Part Number Series T77310

The **AI-Tek Tachtrol 3** computing tachometer is a single or dual channel instrument. It measures input frequencies and displays the resulting quantities in RPM, FPM, % Draw or other rates.

Measurement using the period mode (time per event) permits a combination of fast response and high accuracy not available in other industrial speed instruments. A unique method of setting conversion factors and instrument functions permits it to be easily configured or altered anytime during the instrument life.

### Features & Advantages

- Single or dual channel
- 9 computed functions
- Measures speed or frequency (2 Hz to 30,000 Hz)
- Adjustable normalization
- Active or passive sensor inputs
- Auto ranging LED display
- AC or DC power
- Panel mount DIN housing

- Function indicators
- 2 relay setpoints
- 4-20 mA, 0-20 mA outputs
- 0-10 Vdc, 0-5 Vdc output
- RS232C serial output
- Expanded and suppressed scale analog outputs
- Optional industrial housings
- Easily re-configured
- ±.05% display and relay accuracy
- 100-200 millise. response
- Field adjustable conversion factors
- MIL 810C vibration and shock
- 0-50°C operating temperature
- Mixed output functions

### Applications

A Tachtrol 3 unit is typically used with magnetic sensors as a signal source. However, it may receive a sine wave or TTL signal from any frequency source. The resulting speed or computed function is used for display, alarm or other transmission. It will be superior in applications requiring fast update times and high accuracies. As this instrument

may be re-configured easily, it should be used when scaling factors are subject to change (requirement changes, roll wear, etc.). Certain constant settings produce outputs very useful to very specific applications. *Here are some examples:*

- Fast response overspeed shutdown
- 2 Channel Speed/Draw Monitor
- Bi-directional Tachometer
- Reverse Rotation Alarm
- Low Speed Tachometer
- Clutch Slip Alarm
- Winder Control
- Ahead/Astern Marine Tachometer
- Expanded Analog Scale Speed Transmitter
- Flow Rate Monitor
- Process Time Monitor
- Time per Event Monitor
- Autoranging Tachometer
- Computer Signal Conditioner
- Averaging Tachometer
- Line Frequency Monitor 60.00 Hz/400.0 Hz
- RS232 Speed Transmitter

Ordering P/N	Input Power	Enclosure	Net Weight (lbs.)
T77310 -01	120 Vac/24 Vdc	† Less Encl. } For Explosion Proof	3.3
-02	240 Vac/24 Vdc	† Less Encl. } or NEMA 4X	3.3
-11	120 Vac/24 Vdc	Std. Panel Mount	2.6
-12	240 Vac/24 Vdc	Std. Panel Mount	2.6
-21	120 Vac/24 Vdc	Splashproof Panel Mount	2.7
-22	240 Vac/24 Vdc	Splashproof Panel Mount	2.7
-41	120 Vac/24 Vdc	NEMA 4X *	4.5
-42	240 Vac/24 Vdc	NEMA 4X *	4.5
-71	120 Vac/24 Vdc	Explosion Proof **	39.0
-72	240 Vac/24 Vdc	Explosion Proof **	39.0

† See page 18 for dimensions

\* See page 16 for dimensions

\*\* See page 17 for dimensions

*It is the customer's responsibility to determine whether the product is proper for customer's use and application.*

## Operation

The Tachtrol 3 unit may be configured for measurement of a single speed signal, two unrelated speeds or a speed with direction indication (from an AI-Tek bi-directional sensor). In addition, a mathematical function may be computed from two related input signals. These computed functions are:

- Speed A
- Speed B
- A/B (Ratio)
- $\pm A$  (Speed with direction)
- $(A + B)/2$  (Average)
- A-B (Difference)
- B/A (Inverse Ratio)

- $(A-B)/A \times 100$  (% Slip)
- $(B-A)/A \times 100$  (% Elongation)

The Tachtrol 3 unit permits independent assignment of any of these functions to any output (display, analog output and 1 or 2 setpoints). Additionally, the serial digital output may report on any or all outputs continuously or on setpoint alarm. All forms of relay logic are field selectable.

The Tachtrol 3 unit is supplied with an electrically alterable read only memory (EAROM) which

contains all of the constants necessary to define the conversion factors and instrument functions. These constants can be individually displayed and altered by a method similar to the setting of a digital clock.

By utilizing a microcomputer as the heart of the instrument, response time is improved tenfold over the traditional EPUT (events per unit time) tachometry. Further, this fast response time is attained with no sacrifice in digital accuracy.

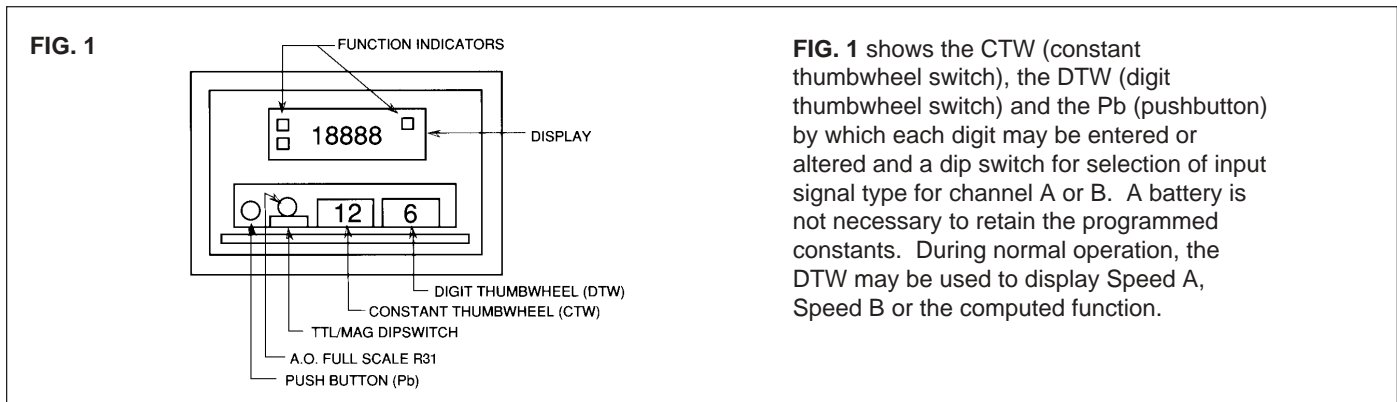

**FIG. 1** shows the CTW (constant thumbwheel switch), the DTW (digit thumbwheel switch) and the Pb (pushbutton) by which each digit may be entered or altered and a dip switch for selection of input signal type for channel A or B. A battery is not necessary to retain the programmed constants. During normal operation, the DTW may be used to display Speed A, Speed B or the computed function.

## Product Application Guidelines

The part number specifies the hardware. Individual requirements for setpoints, scaling and functions may be set into the instrument during installation. The following is a guide from which data to be entered may be supplied.

### Input Frequency

Typically, an input frequency is sensed from rotating gear teeth. Frequency may be obtained from RPM by the formula:

$$f \text{ (in Hz)} = \frac{\text{RPM} \times \text{PPR}}{60}$$

where PPR = pulses per revolution = no. of gear teeth.

The normalization or scaling factor (SF) to be specified may now be obtained for each input by:

$$\text{SF} = \frac{\text{DISPLAY VALUE (RPM, FPM, etc.)}}{\text{INPUT FREQUENCY (Hz)}}$$

The desired form, as an example, is:

- Input A: 2000 Hz = 800 FPM
- Input B: 1600 Hz = 800 FPM

### Outputs

The TACHTROL 3 can transmit any of the 6 computed functions, speed A, or speed B, or speed A with direction to any of the 4 outputs. You may specify

one function for each output. Here are the possibilities:

Outputs	Selective Function	Function
Display	-----	Speed A
Analog	-----	Speed B
Relay 1	-----	A - B
Relay 2	-----	$\pm A$ (dir.)
		A/B
		$(A + B)/2$
		$(A - B)/A \times 100$
		$(B - A)/A \times 100$

If one of the outputs is not used, a tenth function, coded O, may be specified, turning the specific output off.

### Analog Output

The zero and full scale for the analog output can be programmed to normal or expanded scale, such as:

- 4-20 mA = 0 to 900 FPM or
- 4-20 mA = 450 - 900 FPM

### Serial Digital Output

The serial digital (RS232C) output may transmit the value on the display, the analog output value, the two setpoint deviations or all four of these values. They may be continuously transmitted or transmitted on setpoint alarm.

An example of the outputs specified is:  
Display: A/B

Analog output: Speed A  
RS232C: Transmit all values.  
Setpoint 1: A/B

### Relays

Each relay may operate on Input A, Input B or the computed function. They may energize, de-energize, latch or auto-reset at the setpoint. Hysteresis (difference between setpoint value and setpoint reset) is normally 5% but may be specified for any value from 1% to 99% of setpoint.

A typical example for a Tachtrol 3 application is:

- Input A: 2000 Hz = 800 FPM
- Input B: 1600 Hz = 800 FPM
- Display: A/B

Analog output: Speed A=0-900 FPM  
=4-20mA

Setpoint 1: Energize at 1.00 ratio & above with 1% hysteresis

Setpoint 2: Not used

Serial output: Transmit all values continuously.

This specific example is intended as a guide. The versatility of the Tachtrol 3 unit permits several approaches to configuration. Unavailable information may be omitted as it could be supplied during installation. More detailed information is available in the Tachtrol 3 Instruction Manual.

# Specifications

## Input Signals

**Frequency:** 2 Hz to 30K Hz

### Passive Sensor (sine wave):

200 mV to 25 Vrms standard 2D ohm impedance, common mode rejection: 40 db, balanced input sensitivity measured at 1K Hz.

**Active Sensor (TTL):** duty cycle 20 to 80%, DC sensor power is 12 Vdc @ 100 mA [will power two (2) zero velocity sensors or one (1) bi-directional sensor].

**Bi-Directional Sensor:** One (1) frequency input (TTL input A) and the direction input (TTL Input B) from a bi-directional sensor. [High (+5v) indicates positive direction, and only single speed functions (Speed A) are useful when connected in this operation mode.]

## Power Supply

120 Vac±10%, 50-60 Hz  
24 Vdc (23-30 V) std. 750 ohm analog load or (20-30 V) with 600 ohm analog load. 15 watts maximum power.

## Temperature:

0 to 50°C operating  
-40° to 80°C storage

## Humidity:

90% relative and non-condensing

## Vibration:

Designed to meet MIL 810C, method 514.2. Procedure VIII. Fig. 514.2-6. Curve V (1.5 g's. 10-200 Hz).

## Shock:

Disigned to meet MIL 810C, method 516.2. Procedure I Fig. 516.2-2 for ground equipment (30 g's. half sine).

## Displays:

4 1/2 digit with minus sign & decimals (positive direction indicated by no minus sign).  
Bright .56" Red LED  
Fixed or floating decimal (3 places)

Number range ±0.000 to ±19999  
Three (3) LED function indicator lamps.

## Outputs

**Analog:** 0-20 mA or 4-20 mA, field selectable, output consists of one thousand 20 µA steps. 750 ohm load maximum. Span pot-adjustable ±10%. Zero and full scale set into memory in engineering units.  
0-10 Vdc or 0-5 Vdc output obtained by selecting the 0-20mA mode and using a resistor across the input of the receiving instrument whose parallel combination with the input resistance of the receiver is 500 ohms or 250 ohms respectively.

**Serial Digital:** RS232C compatible transmit only ASCII. 300 baud. asynchronous with odd parity. 2 stop bits and carriage return. Transmission format selectable to transmit continuously or on any setpoint alarm. Transmission preceded by linefeed (Lf) and followed by carriage return (Cr). Each value consists of a space (Ø), a two (2) digit identifier, a colon and a right justified (7) character field of data (4 1/2 digit number, sign and decimal) Plus (+) sign, and leading zeros indicated by spaces (bbb). The following are examples of the four (4) type transmissions:  
LfbDO: (display value) Cr  
LfbAO: (analog output value) Cr  
LfbS1: (SP 1 value) bS2 (SP 2 value) CR (SP value = difference between setpoint and actual)

LfbDO: -19.999bAC: b199.99bSP1: bbb-999bSP2:bbb0.00Cr

**Relay Setpoints:** 2 relays standard, SPDT, 6A @ 28 Vdc or 240 Vac, 170W or 1800 VA. Selective relay logic: Energize or de-energize above or below setpoint, auto-reset with hysteresis selectable 0-99% in 1% steps, latching (reset by pushbutton located behind front panel door).

**Accuracy:** (including temp. variations)  
Digital ±.03% typical (±.05% max.) & ± 1 least significant digit  
Analog ±.3% of range

## Response Times:

**Display** updated approx. every 1/2 sec. based on latest available input measurement(s).

**Serial Output:** Transmits each output value in approx. 1/2 second based on input measurements obtained at the time each value is transmitted.

**Analog & Relay Outputs** updated at a variable rate depending on the frequency. the typical & maximum response times are:

Above 100 Hz = 100 ms typical  
200 ms max.  
2 to 100 Hz = 2 cycles + 30 ms typ.  
6 cycles + 30 ms max.

Below 2 Hz = Measurement considered 0  
For values computed from both signal inputs a new computed value is updated each time either signal completes a measurement.

**Range of Normalization** (linear or inverse only)

Input frequencies A & B may be normalized by a number from .5000 x 10<sup>-7</sup> to 2.000 x 10<sup>7</sup>

Normalization is entered in the form:  
+1XXXXX  
-1XXXXX

Additional display normalization range ±.001 to 19999.

## Constant Storage:

Retained in EAROM and may be altered 1000 or more times.

## Electrical References:

Circuit Common is isolated from AC power, analog and case.  
DC power analog output and serial output are referenced to circuit common. Passive inputs are balanced. Active sensor inputs are referenced to circuit common.

## Electrical Connections

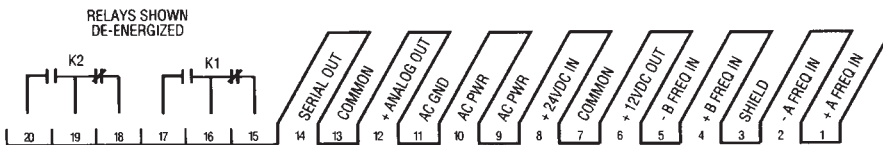

## Panel Mounting Dimensions

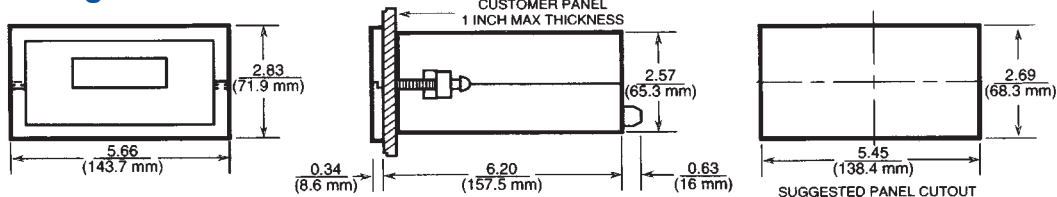

Dimensions in inches and (mm)

## Enclosure Options

The following NEMA rated and hazardous location enclosures are available for certain AI-Tek Instruments tachometer products found in this catalog. When ordering an instrument and enclosure, the instrument will be mounted within the enclosure ready for your application.

The dimensions below will aid you in determining the mounting configuration for each enclosure. Contact your sales representative or factory to answer questions on your specific applications.

### NEMA 4X

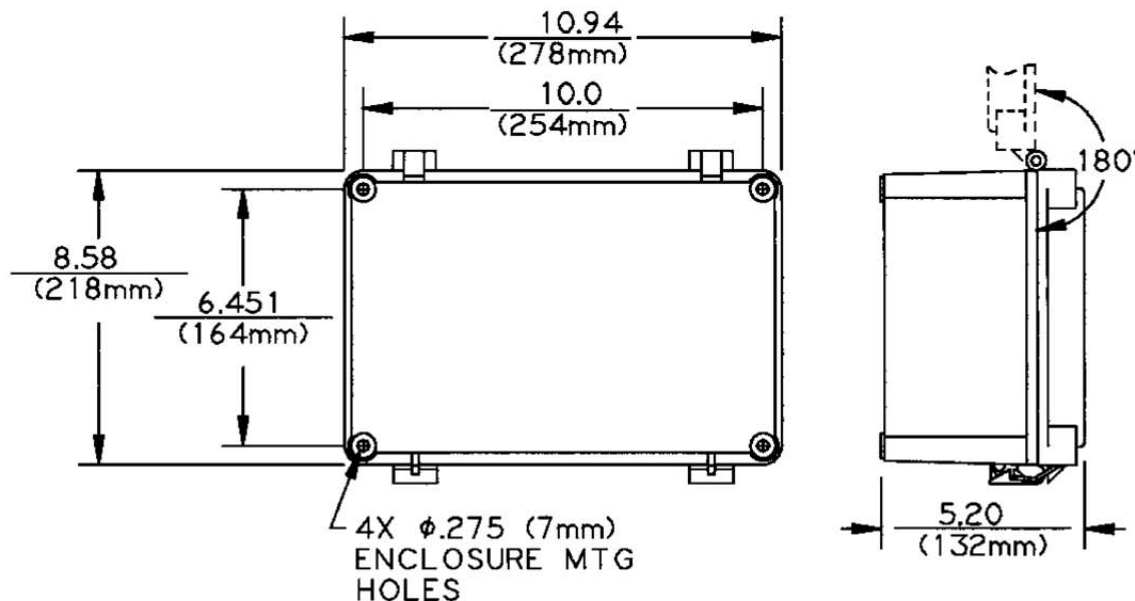

### Tachtrol 3



### NEMA 4X

Meets the requirements of NEMA 3, 12, 4 and 4X. Tachtrol 3 illustrated above.

Dimensions in inches and (mm).

## X STYLE

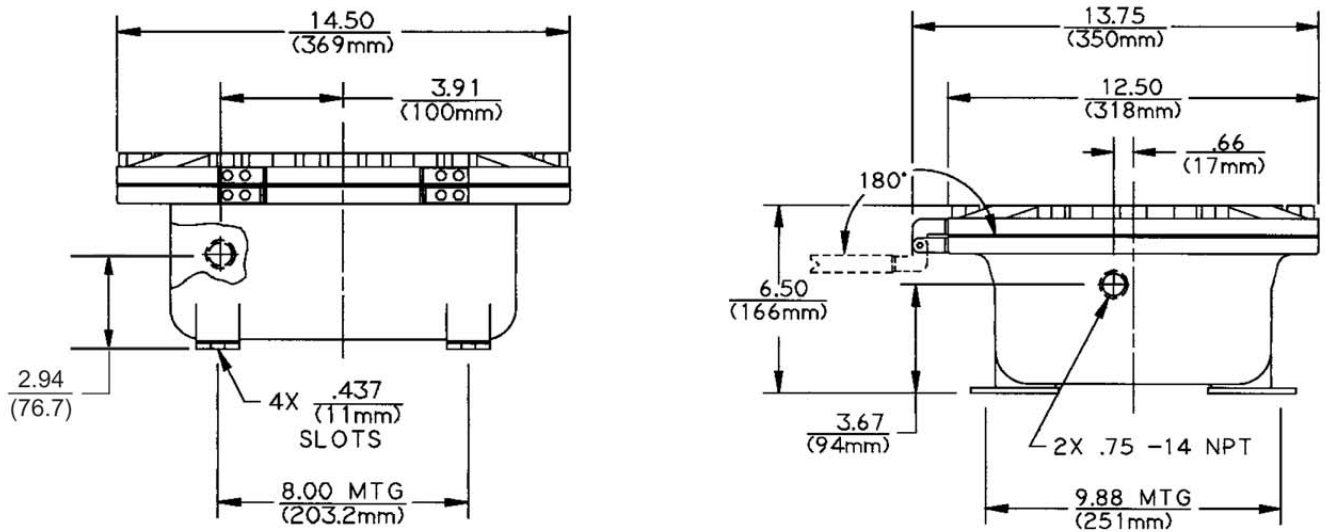

### X STYLE

Meets the explosion-proof requirements of hazardous locations, Class 1, Division 1, Groups B,C & D; Class II, Division 1, Groups E,F & G. Also meets NEMA 3, 4, 7 & 9.

Dimensions in inches and (mm).

### Tachtrol 3 Less Enclosure

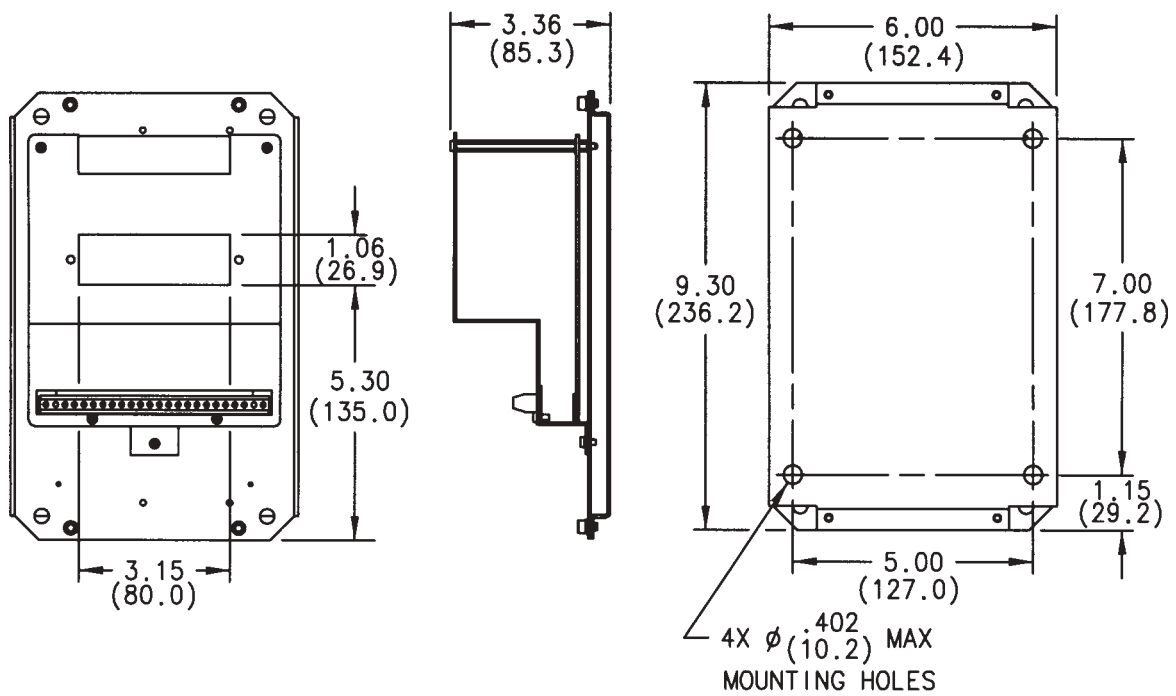

T77310-01 & -02