

Products for Hydrogen Systems

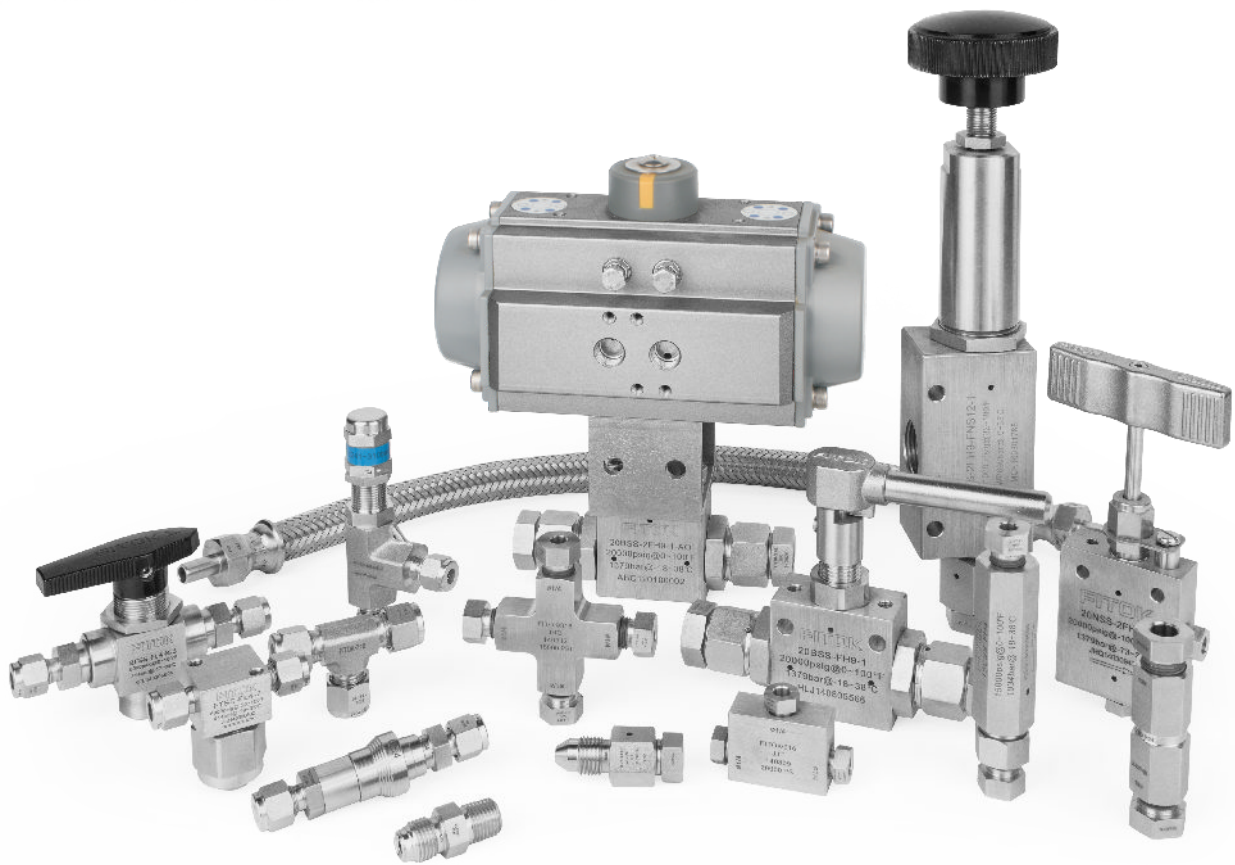

FITOK

www.fitok.com



Introduction

Hydrogen is a flammable, explosive gas with thin molecular structure. It is widely used in petroleum refining, glass purification, semiconductor manufacturing, fertilizer production, aerospace, coolant for power plants and fuel cell application. Fuel cell vehicles include trucks (35 MPa hydrogen) and passenger cars (70 MPa hydrogen). Comparing to other applications, the application of hydrogen system on vehicles is more critical due to the vibration and temperature cycling, as well as the personal safety concerns. To manage and control the quality and safety level of the hydrogen system on vehicles, European Union has developed the Regulation (EC) No 79 in 2009. Now EC79 is the most popular certification for the hydrogen system on vehicles.

To ensure the high level of quality and safety for hydrogen system, FITOK has applied a higher standard in designing, manufacturing and testing. The higher standard covers the raw material specification, brands of resilient sealing parts, tolerance and surface roughness of machined parts, inspection and testing specification, and the EC79 certification.

FITOK products for hydrogen systems are optional by three types:

- Part numbers suffixed with **-EC79** are for on-vehicle hydrogen systems requiring EC79 certification and for critical hydrogen applications.
- Part numbers suffixed with **-H2** are for on-vehicle hydrogen systems not requiring EC79 certification and for critical hydrogen applications (For tubing for critical hydrogen applications, please refer to the part numbers in this catalog, and **-H2** suffix is not required).
- Standard part numbers without a suffix are for non-critical hydrogen applications.

Products for Hydrogen Powered Vehicles

EC79 certification is mandatory in Europe

- *6D Series Tube Fittings / 05*
- *6P Series Pipe Fittings / 16*
- *20D Series Tube Fittings / 19*
- *Ball Valves / 30*
- *Needle Valves / 35*
- *Check Valves / 39*
- *Excess Flow Valves / 46*
- *Filters / 47*
- *Quick-Connects / 51*
- *Metal Hoses / 53*
- *Tubing / 56*



On-road Vehicles

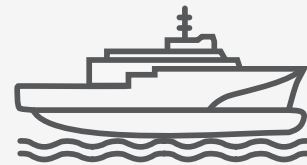

Marine Vessels

Products for Infrastructure Applications

EC79 certification is not required for these applications in Europe and any applications outside Europe

- *6D Series Tube Fittings / 05*
- *6P Series Pipe Fittings / 16*
- *20D Series Tube Fittings / 19*
- *20M Series Medium Pressure Fittings / 23*
- *PMH Series Pipe Fittings / 25*
- *AMH Series Adapter Fittings / 27*
- *BF, BU, 15B Series Ball Valves / 30*
- *NF, 15N, 20N Series Needle Valves / 35*
- *CH, 15C, 20C Series Check Valves / 39*
- *RO, RV, RL Series Proportional Relief Valves / 42*
- *HSR Series Relief Valves / 45*
- *EV Series Excess Flow Valves / 46*
- *FT, 15FC, 20FC Series Filters / 48*
- *QC Series Quick-Connects / 52*
- *MH, MM Series Metal Hoses / 54*
- *Tubing / 56*

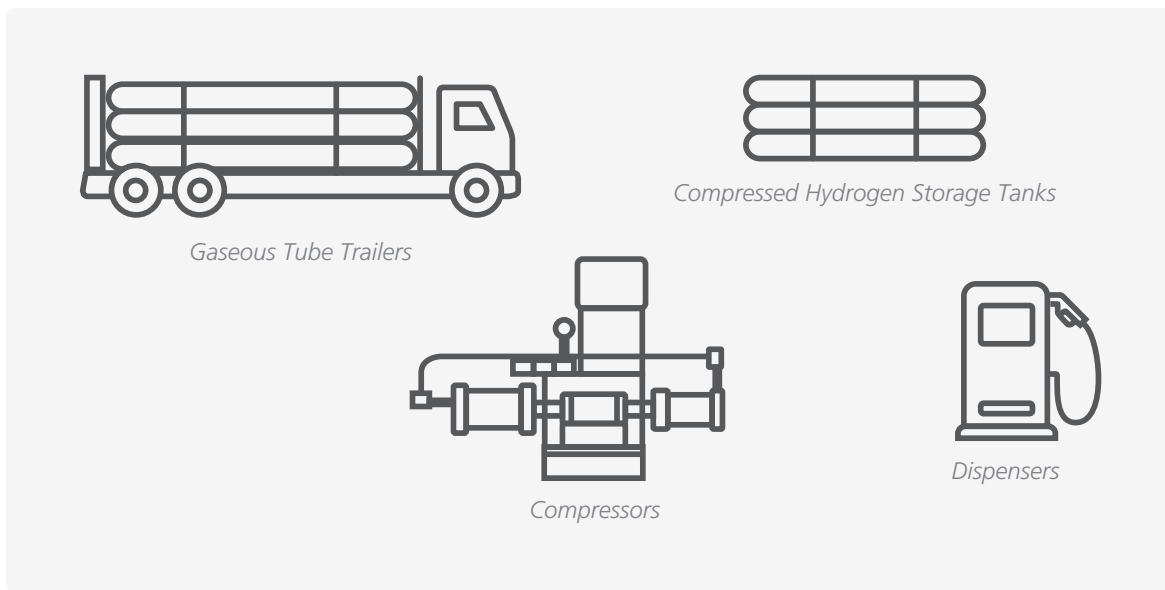

Products

Fittings	03
Valves	29
Filters	47
Quick-Connects	51
Metal Hoses	53
Tubing	56
Other Related Products	64

Certifications

EC79 Approval & Certificates	65
------------------------------	----

Fittings



General Information

End Connection Type, Designator and Leakage Rate

End Connection Type (Designator)	Connecting to (Designator)	Leakage Rate
6D Series Tube Fittings (FL/ML)	TMP or TCT Series Tubing (TMP/TCT)	$\leq 10^{-11}$ Pa m ³ /s
Male NPT (NS)	Female NPT (FNS)	$\leq 10^{-10}$ Pa m ³ /s
SAE-Light Duty (ST)	Port ISO 11926-1 (US)	$\leq 10^{-10}$ Pa m ³ /s
SAE-Heavy Duty (SH)	Port ISO 11926-1 (US)	$\leq 10^{-10}$ Pa m ³ /s
20D Series Tube Fittings (DFF)	T15 or T20D Series Tubing (T15/T20D)	$\leq 10^{-11}$ Pa m ³ /s
20M Series Medium Pressure Fittings (MF)	T20M Series Tubing (T20M)	$\leq 10^{-10}$ Pa m ³ /s

FL/ML

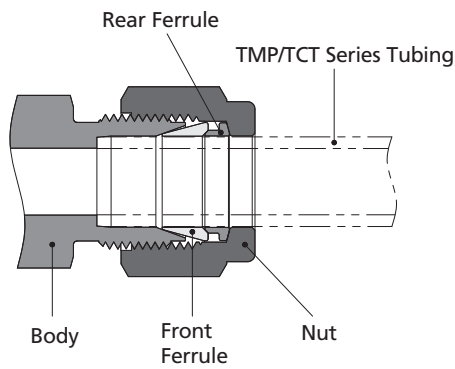

NS

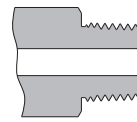

FNS

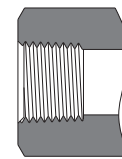

ST, SH

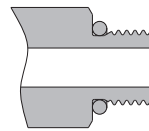

US

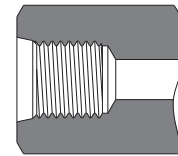

DFF (20D Series Tube Fittings)

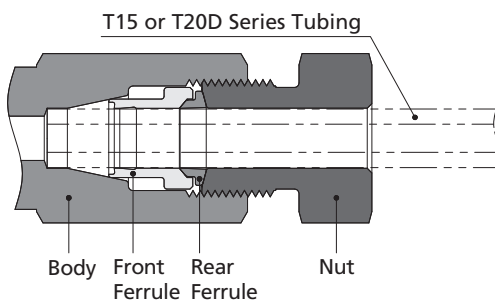

MF (20M Series Medium Pressure Fittings)

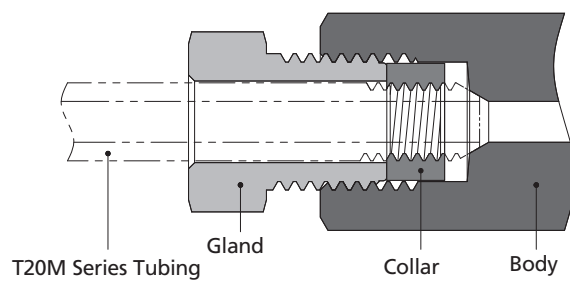

6D Series Tube Fittings

Features

- ◎ FITOK's enhanced-316/316L stainless steel is available upon request for better hydrogen embrittlement resistance
- ◎ Higher manufacturing and inspection standards
- ◎ Compatible with any ASTM A269 tubing. For the highest level of performance, use with FITOK TMP and TCT series tubing
- ◎ Low-temperature fluorocarbon O-ring complies with EC79 standards
- ◎ EC79 approval of 35 MPa hydrogen system application for tube fittings no more than 5/8 in. (16mm)

Technical Data

Body Material	316 SS		
Working Pressure	Thread Size	NPT/ISO Tapered Ends, psig (bar)	
		Male	Female
	1/4	8000 (551)	6600 (454)
	3/8	7800 (537)	5300 (365)
	1/2	7700 (530)	4900 (337)
	3/4	7300 (502)	4600 (316)
	Thread Size	SAE/MS Thread Ends, psig (bar)	
		Light-duty	Heavy-duty
	7/16-20	5075 (350)	—
	1/2-20	5075 (350)	—
9/16-18	5075 (350)	—	
3/4-16	—	5075 (350)	
Working Temperature	Tube: -325~1000 °F (-198~537 °C) NPT/ISO Tapered: -325~400 °F (-198~204 °C) SAE: -40~400 °F (-40~204 °C)		

Note: The maximum working pressure of the tube end is determined by the maximum working pressure of the tubing that is used, please refer to *FK-FC-G-01 FITOK Full Technical Catalog for General Instrumentation*.

Ordering Information and Marking

To order a fitting with EC79 certification for hydrogen-powered vehicles, add **-EC79** at the end of the standard part number. The marking on the fitting is shown as below:

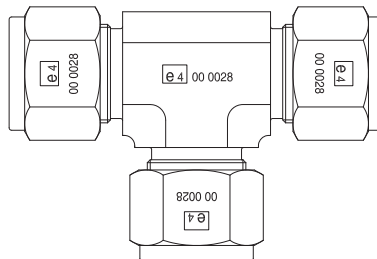

Marking on EC9 Certified Tube Fittings

To order a fitting that does not require EC79 certification for hydrogen systems, add **-H2** at the end of the standard part number. The marking on the fitting is the same as FITOK standard tube fitting. The full part number is labelled on the box.

Products not listed in this catalog may also be suitable for hydrogen applications, please contact FITOK Group or an authorized FITOK distributor.

Male Connectors

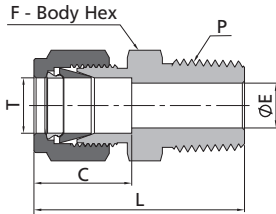

Fractional Tube			NPT Thread			
Basic Ordering Number	T-Tube O.D. (in.)	P-NPT Size	Dimensions, in. (mm)			
			L	C	E (min.)	F
SS-CM-FL4-NS4-	1/4	1/4	1.49 (37.8)	0.60 (15.2)	0.19 (4.8)	0.56 (14.3)
SS-CM-FL4-NS6-	1/4	3/8	1.51 (38.4)	0.60 (15.2)	0.19 (4.8)	0.69 (17.5)
SS-CM-FL4-NS8-	1/4	1/2	1.76 (44.7)	0.60 (15.2)	0.19 (4.8)	0.87 (22.2)
SS-CM-FL5-NS4-	5/16	1/4	1.52 (38.6)	0.64 (16.3)	0.25 (6.4)	0.56 (14.3)
SS-CM-FL5-NS6-	5/16	3/8	1.54 (39.1)	0.64 (16.3)	0.25 (6.4)	0.69 (17.5)
SS-CM-FL5-NS8-	5/16	1/2	1.79 (45.5)	0.64 (16.3)	0.25 (6.4)	0.87 (22.2)
SS-CM-FL6-NS4-	3/8	1/4	1.57 (39.9)	0.66 (16.8)	0.28 (7.1)	0.63 (15.9)
SS-CM-FL6-NS6-	3/8	3/8	1.57 (39.9)	0.66 (16.8)	0.28 (7.1)	0.69 (17.5)
SS-CM-FL6-NS8-	3/8	1/2	1.82 (46.2)	0.66 (16.8)	0.28 (7.1)	0.87 (22.2)
SS-CM-FL8-NS4-	1/2	1/4	1.71 (43.4)	0.90 (22.9)	0.28 (7.1)	0.81 (20.6)
SS-CM-FL8-NS6-	1/2	3/8	1.71 (43.4)	0.90 (22.9)	0.38 (9.7)	0.81 (20.6)
SS-CM-FL8-NS8-	1/2	1/2	1.93 (49.0)	0.90 (22.9)	0.41 (10.4)	0.87 (22.2)
SS-CM-FL10-NS4-	5/8	1/4	1.74 (44.2)	0.96 (24.4)	0.28 (7.1)	0.94 (23.8)
SS-CM-FL10-NS6-	5/8	3/8	1.74 (44.2)	0.96 (24.4)	0.38 (9.7)	0.94 (23.8)
SS-CM-FL10-NS8-	5/8	1/2	1.93 (49.0)	0.96 (24.4)	0.47 (11.9)	0.94 (23.8)

Metric Tube			NPT Thread			
Basic Ordering Number	T-Tube O.D. (mm)	P-NPT Size	Dimensions, mm (in.)			
			L	C	E (min.)	F
SS-CM-ML6-NS4-	6	1/4	37.9 (1.49)	15.3 (0.60)	4.8 (0.19)	14.0 (0.55)
SS-CM-ML6-NS6-	6	3/8	38.4 (1.51)	15.3 (0.60)	4.8 (0.19)	18.0 (0.71)
SS-CM-ML6-NS8-	6	1/2	44.7 (1.76)	15.3 (0.60)	4.8 (0.19)	22.0 (0.87)
SS-CM-ML8-NS4-	8	1/4	38.7 (1.52)	16.2 (0.64)	6.4 (0.25)	15.0 (0.59)
SS-CM-ML8-NS6-	8	3/8	39.3 (1.55)	16.2 (0.64)	6.4 (0.25)	18.0 (0.71)
SS-CM-ML8-NS8-	8	1/2	45.6 (1.80)	16.2 (0.64)	6.4 (0.25)	22.0 (0.87)
SS-CM-ML10-NS4-	10	1/4	40.9 (1.61)	17.2 (0.68)	7.1 (0.28)	18.0 (0.71)
SS-CM-ML10-NS6-	10	3/8	40.9 (1.61)	17.2 (0.68)	7.9 (0.31)	18.0 (0.71)
SS-CM-ML10-NS8-	10	1/2	46.5 (1.83)	17.2 (0.68)	7.9 (0.31)	22.0 (0.87)
SS-CM-ML12-NS4-	12	1/4	43.4 (1.71)	22.8 (0.90)	7.1 (0.28)	22.0 (0.87)
SS-CM-ML12-NS6-	12	3/8	43.4 (1.71)	22.8 (0.90)	9.5 (0.37)	22.0 (0.87)
SS-CM-ML12-NS8-	12	1/2	49.0 (1.93)	22.8 (0.90)	9.5 (0.37)	22.0 (0.87)
SS-CM-ML14-NS4-	14	1/4	44.1 (1.74)	24.4 (0.96)	7.1 (0.28)	24.0 (0.94)
SS-CM-ML14-NS6-	14	3/8	44.1 (1.74)	24.4 (0.96)	9.5 (0.37)	24.0 (0.94)
SS-CM-ML14-NS8-	14	1/2	49.0 (1.93)	24.4 (0.96)	11.1 (0.44)	24.0 (0.94)

Male Connectors

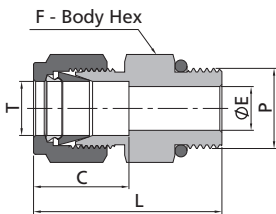

Adapt to straight thread boss of SAE J1926-1, ISO 11926-1 and MS 16142.

Fractional Tube			SAE/MS Straight Thread				
Basic Ordering Number	T-Tube O.D. (in.)	P-SAE Nominal Size	P-SAE/MS Thread Specification	Dimensions, in. (mm)			
				L	C	E (min.)	F
SS-CM-FL4-ST7-	1/4	4	7/16-20	1.34 (34.0)	0.60 (15.2)	0.19 (4.8)	0.56 (14.3)
SS-CM-FL4-ST9-	1/4	6	9/16-18	1.40 (35.6)	0.60 (15.2)	0.19 (4.8)	0.69 (17.5)
SS-CM-FL4-SH12-	1/4	8	3/4-16	1.48 (37.6)	0.60 (15.2)	0.19 (4.8)	0.87 (22.2)
SS-CM-FL6-ST7-	3/8	4	7/16-20	1.40 (35.6)	0.66 (16.8)	0.20 (5.1)	0.63 (15.9)
SS-CM-FL6-ST9-	3/8	6	9/16-18	1.46 (37.1)	0.66 (16.8)	0.28 (7.1)	0.69 (17.5)
SS-CM-FL6-SH12-	3/8	8	3/4-16	1.54 (39.1)	0.66 (16.8)	0.28 (7.1)	0.87 (22.2)
SS-CM-FL8-ST9-	1/2	6	9/16-18	1.54 (39.1)	0.90 (22.9)	0.28 (7.1)	0.81 (20.6)
SS-CM-FL8-SH12-	1/2	8	3/4-16	1.65 (41.9)	0.90 (22.9)	0.41 (10.4)	0.87 (22.2)
SS-CM-FL10-SH12-	5/8	8	3/4-16	1.65 (41.9)	0.96 (24.4)	0.42 (10.7)	0.94 (23.8)

Metric Tube			SAE/MS Straight Thread			
Basic Ordering Number	T-Tube O.D. (mm)	P-SAE/MS Thread Size	Dimensions, mm (in.)			
			L	C	E (min.)	F
SS-CM-ML6-ST7-	6	7/16-20	33.1 (1.30)	15.3 (0.60)	4.8 (0.19)	14.0 (0.55)
SS-CM-ML6-ST9-	6	9/16-18	35.6 (1.40)	15.3 (0.60)	4.8 (0.19)	18.0 (0.71)
SS-CM-ML8-ST7-	8	7/16-20	35.4 (1.39)	16.3 (0.64)	5.1 (0.20)	18.0 (0.71)
SS-CM-ML8-ST9-	8	9/16-18	36.1 (1.42)	16.3 (0.64)	6.4 (0.25)	18.0 (0.71)
SS-CM-ML10-ST7-	10	7/16-20	36.2 (1.43)	17.2 (0.68)	5.1 (0.20)	18.0 (0.71)
SS-CM-ML10-ST9-	10	9/16-18	37.3 (1.47)	17.2 (0.68)	7.1 (0.28)	18.0 (0.71)
SS-CM-ML10-SH12-	10	3/4-16	39.4 (1.55)	17.2 (0.68)	7.9 (0.31)	22.0 (0.87)
SS-CM-ML12-ST7-	12	7/16-20	40.6 (1.60)	22.8 (0.90)	5.2 (0.20)	22.0 (0.87)
SS-CM-ML12-ST9-	12	9/16-18	39.9 (1.57)	22.8 (0.90)	7.1 (0.28)	22.0 (0.87)
SS-CM-ML12-SH12-	12	3/4-16	41.7 (1.64)	22.8 (0.90)	9.5 (0.37)	22.0 (0.87)

Female Connectors

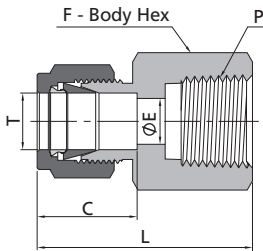

Fractional Tube			NPT Thread			
Basic Ordering Number	T-Tube O.D. (in.)	P-NPT Size	Dimensions, in. (mm)			
			L	C	E	F
SS-CF-FL4-NS4-	1/4	1/4	1.41 (35.8)	0.60 (15.2)	0.19 (4.8)	0.75 (19.1)
SS-CF-FL4-NS6-	1/4	3/8	1.48 (37.6)	0.60 (15.2)	0.19 (4.8)	0.87 (22.2)
SS-CF-FL4-NS8-	1/4	1/2	1.67 (42.4)	0.60 (15.2)	0.19 (4.8)	1.06 (27.0)
SS-CF-FL5-NS4-	5/16	1/4	1.45 (36.8)	0.64 (16.3)	0.25 (6.4)	0.75 (19.1)
SS-CF-FL6-NS4-	3/8	1/4	1.48 (37.6)	0.66 (16.8)	0.28 (7.1)	0.75 (19.1)
SS-CF-FL6-NS6-	3/8	3/8	1.54 (39.1)	0.66 (16.8)	1.34 (7.1)	0.88 (22.2)
SS-CF-FL6-NS8-	3/8	1/2	1.73 (43.9)	0.66 (16.8)	0.28 (7.1)	1.06 (27.0)
SS-CF-FL8-NS4-	1/2	1/4	1.59 (40.4)	0.90 (22.9)	0.41 (10.4)	0.81 (20.6)
SS-CF-FL8-NS6-	1/2	3/8	1.65 (41.9)	0.90 (22.9)	0.41 (10.4)	0.87 (22.2)
SS-CF-FL8-NS8-	1/2	1/2	1.84 (46.7)	0.90 (22.9)	0.41 (10.4)	1.06 (27.0)

Metric Tube			NPT Thread			
Basic Ordering Number	T-Tube O.D. (mm)	P-NPT Size	Dimensions, mm (in.)			
			L	C	E	F
SS-CF-ML6-NS4-	6	1/4	35.8 (1.41)	15.3 (0.60)	4.8 (0.19)	19.0 (0.75)
SS-CF-ML6-NS6-	6	3/8	37.7 (1.48)	15.3 (0.60)	4.8 (0.19)	22.0 (0.87)
SS-CF-ML6-NS8-	6	1/2	42.5 (1.67)	15.3 (0.60)	4.8 (0.19)	27.0 (1.06)
SS-CF-ML8-NS4-	8	1/4	37.0 (1.46)	16.2 (0.64)	6.4 (0.25)	19.0 (0.75)
SS-CF-ML8-NS6-	8	3/8	38.5 (1.52)	16.2 (0.64)	6.4 (0.25)	22.0 (0.87)
SS-CF-ML8-NS8-	8	1/2	43.3 (1.70)	16.2 (0.64)	6.4 (0.25)	27.0 (1.06)
SS-CF-ML10-NS4-	10	1/4	37.8 (1.49)	17.2 (0.68)	7.9 (0.31)	19.0 (0.75)
SS-CF-ML10-NS6-	10	3/8	39.4 (1.55)	17.2 (0.68)	7.9 (0.31)	22.0 (0.87)
SS-CF-ML10-NS8-	10	1/2	44.2 (1.74)	17.2 (0.68)	7.9 (0.31)	27.0 (1.06)
SS-CF-ML12-NS4-	12	1/4	40.3 (1.59)	22.8 (0.90)	9.5 (0.37)	22.0 (0.87)
SS-CF-ML12-NS6-	12	3/8	41.9 (1.65)	22.8 (0.90)	9.5 (0.37)	22.0 (0.87)
SS-CF-ML12-NS8-	12	1/2	46.7 (1.84)	22.8 (0.90)	9.5 (0.37)	27.0 (1.06)

Unions

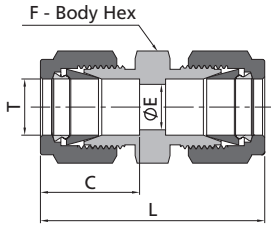

Fractional Tube		Dimensions, in. (mm)			
Basic Ordering Number	T-Tube O.D. (in.)	Dimensions, in. (mm)			
		L	C	E	F
SS-U-FL4-	1/4	1.61 (40.9)	0.60 (15.2)	0.19 (4.8)	0.50 (12.7)
SS-U-FL5-	5/16	1.77 (45.0)	0.66 (16.8)	0.28 (7.1)	0.63 (15.9)
SS-U-FL6-	3/8	2.02 (51.3)	0.90 (22.9)	0.41 (10.4)	0.81 (20.6)
SS-U-FL8-	1/2	2.11 (53.6)	0.96 (24.4)	0.62 (15.7)	1.06 (27.0)
SS-U-FL10-	5/8	2.05 (52.1)	0.96 (24.4)	0.50 (12.7)	0.94 (23.9)

Metric Tube		Dimensions, mm (in.)			
Basic Ordering Number	T-Tube O.D. (mm)	Dimensions, mm (in.)			
		L	C	E	F
SS-U-ML6-	6	41.0 (1.61)	15.3 (0.60)	4.8 (0.19)	14.0 (0.55)
SS-U-ML8-	8	43.2 (1.70)	16.2 (0.64)	6.4 (0.25)	15.0 (0.59)
SS-U-ML10-	10	46.2 (1.82)	17.2 (0.68)	7.9 (0.31)	18.0 (0.71)
SS-U-ML12-	12	51.2 (2.02)	22.8 (0.90)	9.5 (0.37)	22.0 (0.87)
SS-U-ML14-	14	52.0 (2.05)	24.4 (0.96)	11.1 (0.44)	24.0 (0.94)
SS-U-ML15-	15	52.0 (2.05)	24.4 (0.96)	11.9 (0.47)	24.0 (0.94)
SS-U-ML16-	16	52.0 (2.05)	24.4 (0.96)	12.7 (0.50)	24.0 (0.94)

Caps

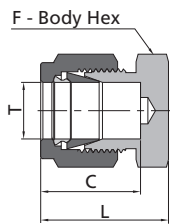

Fractional Tube		Dimensions, in. (mm)		
Basic Ordering Number	T-Tube O.D. (in.)	Dimensions, in. (mm)		
		L	C	F
SS-TC-FL4-	1/4	0.92 (23.4)	0.60 (15.2)	0.50 (12.7)
SS-TC-FL5-	5/16	0.96 (24.4)	0.64 (16.3)	0.56 (14.3)
SS-TC-FL6-	3/8	1.01 (25.7)	0.66 (16.8)	0.63 (15.9)
SS-TC-FL8-	1/2	1.15 (29.2)	0.90 (22.9)	0.81 (20.6)
SS-TC-FL10-	5/8	1.18 (30.0)	0.96 (24.4)	0.94 (23.8)

Metric Tube		Dimensions, mm (in.)		
Basic Ordering Number	T-Tube O.D. (mm)	Dimensions, mm (in.)		
		L	C	F
SS-TC-ML6-	6	23.1 (0.91)	15.3 (0.60)	14.0 (0.55)
SS-TC-ML8-	8	24.5 (0.96)	16.2 (0.64)	15.0 (0.59)
SS-TC-ML10-	10	26.6 (1.05)	17.2 (0.68)	18.0 (0.71)
SS-TC-ML12-	12	29.1 (1.15)	22.8 (0.90)	22.0 (0.87)
SS-TC-ML14-	14	29.9 (1.18)	24.4 (0.96)	24.0 (0.94)
SS-TC-ML15-	15	29.9 (1.18)	24.4 (0.96)	24.0 (0.94)
SS-TC-ML16-	16	29.9 (1.18)	24.4 (0.96)	24.0 (0.94)

Plugs

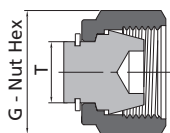

Fractional Tube		Dimensions, in. (mm)
Basic Ordering Number	T-Tube O.D. (in.)	Dimensions, in. (mm)
		G
SS-TP-FL4-	1/4	0.56 (14.3)
SS-TP-FL5-	5/16	0.63 (15.9)
SS-TP-FL6-	3/8	0.69 (17.5)
SS-TP-FL8-	1/2	0.87 (22.2)
SS-TP-FL10-	5/8	1.00 (25.4)

Metric Tube		Dimensions, mm (in.)
Basic Ordering Number	T-Tube O.D. (mm)	Dimensions, mm (in.)
		G
SS-TP-ML6-	6	14.0 (0.55)
SS-TP-ML8-	8	16.0 (0.63)
SS-TP-ML10-	10	19.0 (0.75)
SS-TP-ML12-	12	22.0 (0.87)
SS-TP-ML14-	14	25.0 (0.98)
SS-TP-ML15-	15	25.0 (0.98)
SS-TP-ML16-	16	25.0 (0.98)

Male Adapters

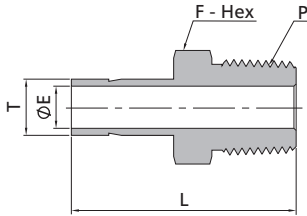

Fractional Tube			NPT Thread		
Basic Ordering Number	T-Tube O.D. (in.)	P-NPT Size	Dimensions, in. (mm)		
			L	E	F
SS-AM-FT4-NS4-	1/4	1/4	1.46 (37.1)	0.17 (4.3)	0.56 (14.3)
SS-AM-FT4-NS6-	1/4	3/8	1.49 (37.8)	0.17 (4.3)	0.69 (17.5)
SS-AM-FT4-NS8-	1/4	1/2	1.71 (43.4)	0.17 (4.3)	0.87 (22.2)
SS-AM-FT5-NS4-	5/16	1/4	1.50 (38.1)	0.22 (5.6)	0.56 (14.3)
SS-AM-FT5-NS6-	5/16	3/8	1.53 (38.9)	0.22 (5.6)	0.69 (17.5)
SS-AM-FT5-NS8-	5/16	1/2	1.74 (44.2)	0.22 (5.6)	0.87 (22.2)
SS-AM-FT6-NS4-	3/8	1/4	1.53 (38.9)	0.27 (6.9)	0.56 (14.3)
SS-AM-FT6-NS6-	3/8	3/8	1.56 (39.6)	0.27 (6.9)	0.69 (17.5)
SS-AM-FT6-NS8-	3/8	1/2	1.78 (45.2)	0.27 (6.9)	0.87 (22.2)
SS-AM-FT8-NS4-	1/2	1/4	1.75 (44.5)	0.28 (7.1)	0.56 (14.3)
SS-AM-FT8-NS6-	1/2	3/8	1.78 (45.2)	0.37 (9.4)	0.69 (17.5)
SS-AM-FT8-NS8-	1/2	1/2	2.00 (50.8)	0.37 (9.4)	0.87 (22.2)

Metric Tube			NPT Thread		
Basic Ordering Number	T-Tube O.D. (mm)	P-NPT Size	Dimensions, mm (in.)		
			L	E	F
SS-AM-MT6-NS4-	6	1/4	38.1 (1.50)	4.1 (0.16)	14.0 (0.55)
SS-AM-MT6-NS6-	6	3/8	39.2 (1.54)	4.1 (0.16)	18.0 (0.71)
SS-AM-MT6-NS8-	6	1/2	42.1 (1.66)	4.1 (0.16)	22.0 (0.87)
SS-AM-MT8-NS4-	8	1/4	39.1 (1.54)	5.6 (0.22)	14.0 (0.55)
SS-AM-MT8-NS6-	8	3/8	39.9 (1.57)	5.6 (0.22)	19.0 (0.75)
SS-AM-MT10-NS4-	10	1/4	39.9 (1.57)	7.1 (0.28)	14.0 (0.55)
SS-AM-MT10-NS6-	10	3/8	40.6 (1.60)	7.1 (0.28)	18.0 (0.71)
SS-AM-MT10-NS8-	10	1/2	46.2 (1.82)	7.1 (0.28)	22.0 (0.87)
SS-AM-MT12-NS4-	12	1/4	46.5 (1.83)	7.1 (0.28)	14.0 (0.55)
SS-AM-MT12-NS6-	12	3/8	46.2 (1.82)	8.8 (0.35)	18.0 (0.71)
SS-AM-MT12-NS8-	12	1/2	52.1 (2.05)	8.8 (0.35)	22.0 (0.87)

Female Adapters

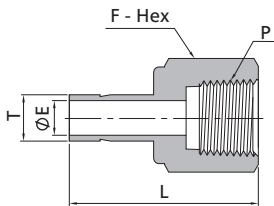

Fractional Tube			NPT Thread		
Basic Ordering Number	T-Tube O.D. (in.)	P-NPT Size	Dimensions, in. (mm)		
			L	E	F
SS-AF-FT4-NS4-	1/4	1/4	1.46 (37.1)	0.17 (4.3)	0.75 (19.1)
SS-AF-FT4-NS6-	1/4	3/8	1.55 (39.4)	0.17 (4.3)	0.87 (22.2)
SS-AF-FT4-NS8-	1/4	1/2	1.79 (45.5)	0.17 (4.3)	1.06 (27.0)
SS-AF-FT5-NS4-	5/16	1/4	1.48 (37.6)	0.22 (5.6)	0.75 (19.1)
SS-AF-FT5-NS6-	5/16	3/8	1.59 (40.4)	0.22 (5.6)	0.87 (22.2)
SS-AF-FT6-NS4-	3/8	1/4	1.50 (38.1)	0.27 (6.9)	0.75 (19.1)
SS-AF-FT6-NS6-	3/8	3/8	1.59 (40.4)	0.27 (6.9)	0.87 (22.2)
SS-AF-FT6-NS8-	3/8	1/2	1.84 (46.7)	0.27 (6.9)	1.06 (27.0)
SS-AF-FT8-NS4-	1/2	1/4	1.71 (43.4)	0.37 (9.4)	0.75 (19.1)
SS-AF-FT8-NS6-	1/2	3/8	1.79 (45.5)	0.37 (9.4)	0.87 (22.2)
SS-AF-FT8-NS8-	1/2	1/2	2.04 (51.8)	0.37 (9.4)	1.06 (27.0)

Metric Tube			NPT Thread		
Basic Ordering Number	T-Tube O.D. (mm)	P-NPT Size	Dimensions, mm (in.)		
			L	E	F
SS-AF-MT6-NS4-	6	1/4	37.1 (1.46)	4.1 (0.16)	19.0 (0.75)
SS-AF-MT8-NS4-	8	1/4	37.6 (1.48)	5.6 (0.22)	19.0 (0.75)
SS-AF-MT8-NS6-	8	3/8	36.5 (1.44)	5.6 (0.22)	22.0 (0.87)
SS-AF-MT10-NS4-	10	1/4	38.1 (1.50)	7.1 (0.28)	19.0 (0.75)
SS-AF-MT10-NS6-	10	3/8	40.1 (1.58)	7.1 (0.28)	22.0 (0.87)
SS-AF-MT10-NS8-	10	1/2	46.5 (1.83)	7.1 (0.28)	27.0 (1.06)
SS-AF-MT12-NS4-	12	1/4	43.7 (1.72)	8.8 (0.35)	19.0 (0.75)
SS-AF-MT12-NS6-	12	3/8	42.9 (1.69)	8.8 (0.35)	22.0 (0.87)
SS-AF-MT12-NS8-	12	1/2	52.3 (2.06)	8.8 (0.35)	27.0 (1.06)

Reducers

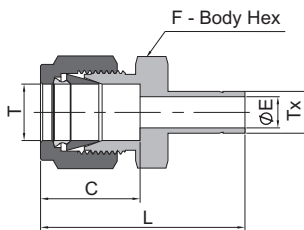

Fractional Tube						
Basic Ordering Number	T-Tube O.D. (in.)	Tx-Tube O.D. (in.)	Dimensions, in. (mm)			
			L	C	E	F
SS-R-FL4-FT4-	1/4	1/4	1.54 (39.1)	0.60 (15.2)	0.17 (4.3)	0.50 (12.7)
SS-R-FL4-FT5-	1/4	5/16	1.57 (39.9)	0.60 (15.2)	0.19 (4.8)	0.50 (12.7)
SS-R-FL4-FT6-	1/4	3/8	1.60 (40.6)	0.60 (15.2)	0.19 (4.8)	0.50 (12.7)
SS-R-FL4-FT8-	1/4	1/2	1.82 (46.2)	0.60 (15.2)	0.19 (4.8)	0.56 (14.3)
SS-R-FL4-FT10-	1/4	5/8	1.89 (48.0)	0.60 (15.2)	0.19 (4.8)	0.69 (17.5)
SS-R-FL5-FT6-	5/16	3/8	1.65 (41.9)	0.64 (16.3)	0.25 (6.4)	0.56 (14.3)
SS-R-FL5-FT8-	5/16	1/2	1.87 (47.5)	0.64 (16.3)	0.25 (6.4)	0.56 (14.3)
SS-R-FL6-FT4-	3/8	1/4	1.63 (41.4)	0.66 (16.8)	0.17 (4.3)	0.63 (15.9)
SS-R-FL6-FT6-	3/8	3/8	1.70 (43.2)	0.66 (16.8)	0.27 (6.9)	0.63 (15.9)
SS-R-FL6-FT8-	3/8	1/2	1.91 (48.5)	0.66 (16.8)	0.28 (7.1)	0.63 (15.9)
SS-R-FL6-FT10-	3/8	5/8	1.98 (50.3)	0.66 (16.8)	0.28 (7.1)	0.69 (17.5)
SS-R-FL8-FT4-	1/2	1/4	1.77 (45.0)	0.90 (22.9)	0.17 (4.3)	0.81 (20.6)
SS-R-FL8-FT6-	1/2	3/8	1.84 (46.7)	0.90 (22.9)	0.27 (6.9)	0.81 (20.6)
SS-R-FL8-FT8-	1/2	1/2	2.06 (52.3)	0.90 (22.9)	0.37 (9.4)	0.81 (20.6)
SS-R-FL8-FT10-	1/2	5/8	2.12 (53.8)	0.90 (22.9)	0.41 (10.4)	0.81 (20.6)

Metric Tube						
Basic Ordering Number	T-Tube O.D. (mm)	Tx-Tube O.D. (mm)	Dimensions, mm (in.)			
			L	C	E	F
SS-R-ML6-MT8-	6	8	39.9 (1.57)	15.3 (0.60)	4.8 (0.19)	14.0 (0.55)
SS-R-ML6-MT10-	6	10	40.7 (1.60)	15.3 (0.60)	4.8 (0.19)	14.0 (0.55)
SS-R-ML6-MT12-	6	12	46.3 (1.82)	15.3 (0.60)	4.8 (0.19)	14.0 (0.55)
SS-R-ML8-MT6-	8	6	40.3 (1.59)	16.2 (0.64)	4.1 (0.16)	15.0 (0.59)
SS-R-ML8-MT10-	8	10	42.0 (1.65)	16.2 (0.64)	6.4 (0.25)	15.0 (0.59)
SS-R-ML8-MT12-	8	12	47.6 (1.87)	16.2 (0.64)	6.4 (0.25)	15.0 (0.59)
SS-R-ML10-MT6-	10	6	42.4 (1.67)	17.2 (0.68)	4.1 (0.16)	18.0 (0.71)
SS-R-ML10-MT8-	10	8	43.4 (1.71)	17.2 (0.68)	5.6 (0.22)	18.0 (0.71)
SS-R-ML10-MT12-	10	12	49.8 (1.96)	17.2 (0.68)	7.9 (0.31)	18.0 (0.71)
SS-R-ML10-MT15-	10	15	51.3 (2.02)	17.2 (0.68)	7.9 (0.31)	18.0 (0.71)
SS-R-ML12-MT6-	12	6	44.9 (1.77)	22.8 (0.90)	4.1 (0.16)	22.0 (0.87)
SS-R-ML12-MT8-	12	8	45.9 (1.81)	22.8 (0.90)	5.6 (0.22)	22.0 (0.87)
SS-R-ML12-MT10-	12	10	46.7 (1.84)	22.8 (0.90)	7.1 (0.28)	22.0 (0.87)
SS-R-ML12-MT16-	12	16	53.8 (2.12)	22.8 (0.90)	9.5 (0.37)	22.0 (0.87)

Port Connectors

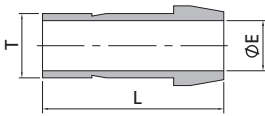

Fractional Tube			
Basic Ordering Number	T-Tube O.D. (in.)	Dimensions, in. (mm)	
		L	E
SS-P-FL4-	1/4	0.97 (24.6)	0.17 (4.3)
SS-P-FL5-	5/16	1.02 (25.9)	0.22 (5.6)
SS-P-FL6-	3/8	1.03 (26.2)	0.27 (6.9)
SS-P-FL8-	1/2	1.41 (35.8)	0.37 (9.4)
SS-P-FL10-	5/8	1.64 (41.7)	0.47 (11.9)

Metric Tube			
Basic Ordering Number	T-Tube O.D. (mm)	Dimensions, mm (in.)	
		L	E
SS-P-ML6-	6	24.6 (0.97)	4.1 (0.16)
SS-P-ML8-	8	25.9 (1.02)	5.6 (0.22)
SS-P-ML10-	10	26.1 (1.03)	7.1 (0.28)
SS-P-ML12-	12	35.8 (1.41)	8.8 (0.35)
SS-P-ML15-	15	37.8 (1.49)	11.2 (0.44)
SS-P-ML16-	16	37.8 (1.49)	12.0 (0.47)

Male Elbows

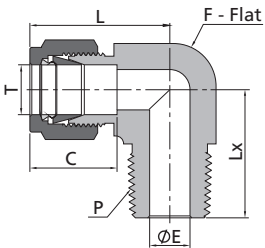

Fractional Tube			NPT Thread				
Basic Ordering Number	T-Tube O.D. (in.)	P-NPT Size	Dimensions, in. (mm)				
			L	C	E	F	Lx
SS-LM-FL4-NS4-	1/4	1/4	1.06 (26.9)	0.60 (15.2)	0.19 (4.8)	0.50 (12.7)	0.92 (23.4)
SS-LM-FL4-NS6-	1/4	3/8	1.17 (29.7)	0.60 (15.2)	0.19 (4.8)	0.69 (17.5)	1.03 (26.2)
SS-LM-FL4-NS8-	1/4	1/2	1.25 (31.8)	0.60 (15.2)	0.19 (4.8)	0.81 (20.6)	1.30 (33.0)
SS-LM-FL5-NS4-	5/16	1/4	1.13 (28.7)	0.64 (16.3)	0.25 (6.4)	0.56 (14.3)	0.96 (24.4)
SS-LM-FL5-NS6-	5/16	3/8	1.20 (30.5)	0.64 (16.3)	0.25 (6.4)	0.69 (17.5)	1.03 (26.2)
SS-LM-FL6-NS4-	3/8	1/4	1.20 (30.5)	0.66 (16.8)	0.28 (7.1)	0.63 (15.9)	1.00 (25.4)
SS-LM-FL6-NS6-	3/8	3/8	1.23 (31.2)	0.66 (16.8)	0.28 (7.1)	0.69 (17.5)	1.03 (26.2)
SS-LM-FL6-NS8-	3/8	1/2	1.31 (33.3)	0.66 (16.8)	0.28 (7.1)	0.81 (20.6)	1.30 (33.0)
SS-LM-FL8-NS4-	1/2	1/4	1.42 (36.1)	0.90 (22.9)	0.28 (7.1)	0.81 (20.6)	1.11 (28.2)
SS-LM-FL8-NS6-	1/2	3/8	1.42 (36.1)	0.90 (22.9)	0.38 (9.7)	0.81 (20.6)	1.11 (28.2)
SS-LM-FL8-NS8-	1/2	1/2	1.42 (36.1)	0.90 (22.9)	0.41 (10.4)	0.81 (20.6)	1.30 (33.0)

Metric Tube			NPT Thread				
Basic Ordering Number	T-Tube O.D. (mm)	P-NPT Size	Dimensions, mm (in.)				
			L	C	E	F	Lx
SS-LM-ML6-NS4-	6	1/4	27.0 (1.06)	15.3 (0.60)	4.8 (0.19)	12.7 (0.50)	23.4 (0.92)
SS-LM-ML6-NS6-	6	3/8	29.8 (1.17)	15.3 (0.60)	4.8 (0.19)	17.5 (0.69)	26.2 (1.03)
SS-LM-ML6-NS8-	6	1/2	31.8 (1.25)	15.3 (0.60)	4.8 (0.19)	20.6 (0.81)	33.0 (1.30)
SS-LM-ML8-NS4-	8	1/4	28.8 (1.13)	16.2 (0.64)	6.4 (0.25)	14.3 (0.56)	24.4 (0.96)
SS-LM-ML8-NS6-	8	3/8	30.6 (1.20)	16.2 (0.64)	6.4 (0.25)	17.5 (0.69)	26.2 (1.03)
SS-LM-ML8-NS8-	8	1/2	32.6 (1.28)	16.2 (0.64)	6.4 (0.25)	20.6 (0.81)	33.0 (1.30)
SS-LM-ML10-NS4-	10	1/4	31.5 (1.24)	17.2 (0.68)	7.1 (0.28)	17.5 (0.69)	26.2 (1.03)
SS-LM-ML10-NS6-	10	3/8	31.5 (1.24)	17.2 (0.68)	7.9 (0.31)	17.5 (0.69)	26.2 (1.03)
SS-LM-ML10-NS8-	10	1/2	33.5 (1.32)	17.2 (0.68)	7.9 (0.31)	20.6 (0.81)	33.0 (1.30)
SS-LM-ML12-NS4-	12	1/4	36.0 (1.42)	22.8 (0.90)	7.1 (0.28)	20.6 (0.81)	28.2 (1.11)
SS-LM-ML12-NS6-	12	3/8	36.0 (1.42)	22.8 (0.90)	9.5 (0.37)	20.6 (0.81)	28.2 (1.11)
SS-LM-ML12-NS8-	12	1/2	36.0 (1.42)	22.8 (0.90)	9.5 (0.37)	20.6 (0.81)	33.0 (1.30)
SS-LM-ML12-NS12-	12	3/4	39.8 (1.57)	22.8 (0.90)	9.5 (0.37)	27.0 (1.06)	36.8 (1.45)

Female Elbows

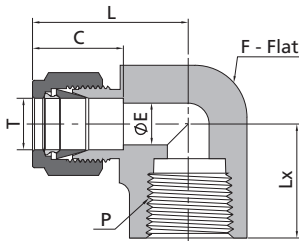

Fractional Tube			NPT Thread				
Basic Ordering Number	T-Tube O.D. (in.)	P-NPT Size	Dimensions, in. (mm)				
			L	C	E	F	Lx
SS-LF-FL4-NS4-	1/4	1/4	1.17 (29.7)	0.60 (15.2)	0.19 (4.8)	0.69 (17.5)	0.88 (22.4)
SS-LF-FL4-NS6-	1/4	3/8	1.25 (31.8)	0.60 (15.2)	0.19 (4.8)	0.81 (20.6)	0.88 (22.4)
SS-LF-FL4-NS8-	1/4	1/2	1.36 (34.5)	0.60 (15.2)	0.19 (4.8)	1.00 (25.4)	1.12 (28.4)
SS-LF-FL5-NS4-	5/16	1/4	1.20 (30.5)	0.64 (16.3)	0.25 (6.4)	0.69 (17.5)	0.88 (22.4)
SS-LF-FL6-NS4-	3/8	1/4	1.23 (31.2)	0.66 (16.8)	0.28 (7.1)	0.69 (17.5)	0.88 (22.4)
SS-LF-FL6-NS6-	3/8	3/8	1.31 (33.3)	0.66 (16.8)	0.28 (7.1)	0.81 (20.6)	0.88 (22.4)
SS-LF-FL6-NS8-	3/8	1/2	1.42 (36.1)	0.66 (16.8)	0.28 (7.1)	1.00 (25.4)	1.12 (28.4)
SS-LF-FL8-NS4-	1/2	1/4	1.42 (36.1)	0.90 (22.9)	0.41 (10.4)	0.81 (20.6)	0.88 (22.4)
SS-LF-FL8-NS6-	1/2	3/8	1.42 (36.1)	0.90 (22.9)	0.41 (10.4)	0.81 (20.6)	0.88 (22.4)
SS-LF-FL8-NS8-	1/2	1/2	1.53 (38.9)	0.90 (22.9)	0.41 (10.4)	1.00 (25.4)	1.12 (28.4)

Metric Tube			NPT Thread				
Basic Ordering Number	T-Tube O.D. (mm)	P-NPT Size	Dimensions, mm (in.)				
			L	C	E	F	Lx
SS-LF-ML6-NS4-	6	1/4	29.8 (1.17)	15.3 (0.60)	4.8 (0.19)	17.5 (0.69)	22.4 (0.88)
SS-LF-ML8-NS4-	8	1/4	30.6 (1.20)	16.2 (0.64)	6.4 (0.25)	17.5 (0.69)	22.4 (0.88)
SS-LF-ML10-NS4-	10	1/4	33.5 (1.32)	17.2 (0.68)	7.9 (0.31)	20.6 (0.81)	22.4 (0.88)
SS-LF-ML10-NS6-	10	3/8	33.5 (1.32)	17.2 (0.68)	7.9 (0.31)	20.6 (0.81)	22.4 (0.88)
SS-LF-ML10-NS8-	10	1/2	36.6 (1.44)	17.2 (0.68)	7.9 (0.31)	25.4 (1.00)	28.5 (1.12)
SS-LF-ML12-NS4-	12	1/4	36.0 (1.42)	22.8 (0.90)	9.5 (0.37)	20.6 (0.81)	22.4 (0.88)
SS-LF-ML12-NS6-	12	3/8	36.0 (1.42)	22.8 (0.90)	9.5 (0.37)	20.6 (0.81)	22.4 (0.88)
SS-LF-ML12-NS8-	12	1/2	38.8 (1.53)	22.8 (0.90)	9.5 (0.37)	25.4 (1.00)	28.4 (1.12)

Union Elbows

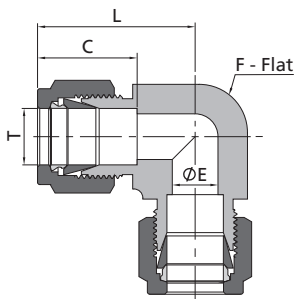

Fractional Tube			NPT Thread			
Basic Ordering Number	T-Tube O.D. (in.)	P-NPT Size	Dimensions, in. (mm)			
			L	C	E	F
SS-LU-FL4-	1/4	1/4	1.06 (26.9)	0.60 (15.2)	0.19 (4.8)	0.50 (12.7)
SS-LU-FL5-	5/16	1/4	1.13 (28.7)	0.64 (16.3)	0.25 (6.4)	0.56 (14.3)
SS-LU-FL6-	3/8	1/4	1.20 (30.5)	0.66 (16.8)	0.28 (7.1)	0.63 (15.9)
SS-LU-FL8-	1/2	1/4	1.42 (36.1)	0.90 (22.9)	0.41 (10.4)	0.81 (20.6)
SS-LU-FL10-	5/8	1/2	1.50 (38.1)	0.96 (24.4)	0.5 (12.7)	0.94 (23.8)

Metric Tube			NPT Thread			
Basic Ordering Number	T-Tube O.D. (mm)	P-NPT Size	Dimensions, mm (in.)			
			L	C	E	F
SS-LU-ML6-	6	1/4	27.0 (1.06)	15.3 (0.60)	4.8 (0.19)	12.7 (0.50)
SS-LU-ML8-	8	1/4	28.8 (1.13)	16.2 (0.64)	6.4 (0.25)	14.3 (0.56)
SS-LU-ML10-	10	1/4	31.5 (1.24)	17.2 (0.68)	7.9 (0.31)	17.5 (0.69)
SS-LU-ML12-	12	1/4	36.0 (1.42)	22.8 (0.90)	9.5 (0.37)	20.6 (0.81)
SS-LU-ML14-	14	1/4	38.0 (1.50)	24.4 (0.96)	11.0 (0.43)	23.8 (0.94)
SS-LU-ML15-	15	1/4	38.0 (1.50)	24.4 (0.96)	11.9 (0.47)	23.8 (0.94)
SS-LU-ML16-	16	1/4	38.0 (1.50)	24.4 (0.96)	12.7 (0.50)	23.8 (0.94)

Union Tees

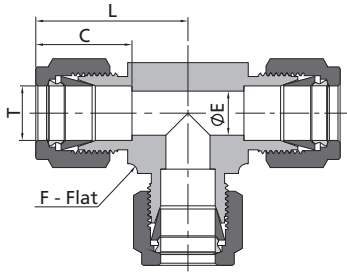

Fractional Tube		Dimensions, in. (mm)			
Basic Ordering Number	T-Tube O.D. (in.)	L	C	E	F
		SS-TTT-FL4-	1/4	1.06 (26.9)	0.60 (15.2)
SS-TTT-FL5-	5/16	1.17 (29.7)	0.64 (16.2)	0.25 (6.4)	0.63 (15.9)
SS-TTT-FL6-	3/8	1.20 (30.5)	0.66 (16.8)	0.28 (7.1)	0.63 (15.9)
SS-TTT-FL8-	1/2	1.42 (36.1)	0.90 (22.9)	0.41 (10.4)	0.81 (20.6)
SS-TTT-FL10-	5/8	1.53 (38.9)	0.96 (24.4)	0.50 (12.7)	1.00 (25.4)

Metric Tube		Dimensions, mm (in.)			
Basic Ordering Number	T-Tube O.D. (mm)	L	C	E	F
		SS-TTT-ML6-	6	27.0 (1.06)	15.3 (0.60)
SS-TTT-ML8-	8	29.9 (1.18)	16.2 (0.64)	6.4 (0.25)	15.9 (0.63)
SS-TTT-ML10-	10	31.5 (1.24)	17.2 (0.68)	7.9 (0.31)	17.5 (0.69)
SS-TTT-ML12-	12	36.0 (1.42)	22.8 (0.90)	9.5 (0.37)	20.6 (0.81)
SS-TTT-ML14-	14	38.8 (1.53)	24.4 (0.96)	11.1 (0.44)	25.4 (1.00)
SS-TTT-ML15-	15	38.8 (1.53)	24.4 (0.96)	11.9 (0.47)	25.4 (1.00)
SS-TTT-ML16-	16	38.8 (1.53)	24.4 (0.96)	12.7 (0.50)	25.4 (1.00)

Male Branch Tees

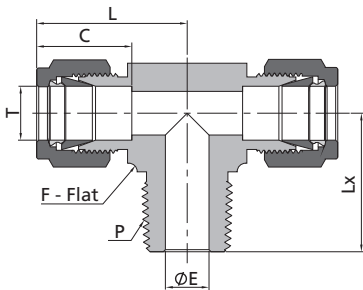

Fractional Tube			NPT Thread				
Basic Ordering Number	T-Tube O.D. (in.)	P-NPT Size	Dimensions, in. (mm)				
			L	C	E (min.)	F	Lx
SS-TTM-FL4-NS4-	1/4	1/4	1.06 (26.9)	0.60 (15.2)	0.19 (4.8)	0.50 (12.7)	0.92 (23.4)
SS-TTM-FL6-NS4-	3/8	1/4	1.20 (30.5)	0.66 (16.8)	0.28 (7.1)	0.63 (15.9)	1.00 (25.4)
SS-TTM-FL6-NS6-	3/8	3/8	1.31 (33.3)	0.66 (16.8)	0.28 (7.1)	0.81 (20.6)	1.11 (28.2)

Metric Tube			NPT Thread				
Basic Ordering Number	T-Tube O.D. (mm)	P-NPT Size	Dimensions, mm (in.)				
			L	C	E (min.)	F	Lx
SS-TTM-ML6-NS4-	6	1/4	27.0 (1.06)	15.3 (0.60)	4.8 (0.19)	12.7 (0.50)	23.4 (0.92)
SS-TTM-ML8-NS4-	8	1/4	29.9 (1.18)	16.2 (0.64)	6.4 (0.25)	15.9 (0.63)	25.4 (1.00)
SS-TTM-ML10-NS4-	10	1/4	33.5 (1.32)	17.2 (0.68)	7.1 (0.28)	20.6 (0.81)	28.2 (1.11)
SS-TTM-ML10-NS6-	10	3/8	33.5 (1.32)	17.2 (0.68)	7.9 (0.31)	20.6 (0.81)	28.2 (1.11)
SS-TTM-ML12-NS4-	12	1/4	36.0 (1.42)	22.8 (0.90)	7.1 (0.28)	20.6 (0.81)	28.2 (1.11)
SS-TTM-ML12-NS6-	12	3/8	36.0 (1.42)	22.8 (0.90)	9.5 (0.37)	20.6 (0.81)	28.2 (1.11)
SS-TTM-ML12-NS8-	12	1/2	36.0 (1.42)	22.8 (0.90)	9.5 (0.37)	20.6 (0.81)	33.0 (1.30)

Male Run Tees

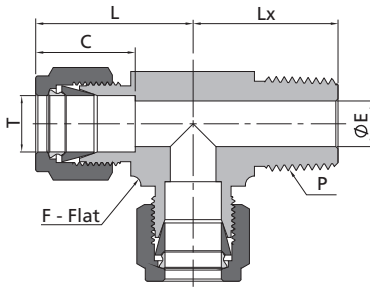

Fractional Tube			NPT Thread				
Basic Ordering Number	T-Tube O.D. (in.)	P-NPT Size	Dimensions, in. (mm)				
			L	C	E (min.)	F	Lx
SS-TMT-FL4-NS4-	1/4	1/4	1.06 (26.9)	0.60 (15.2)	0.19 (4.8)	0.50 (12.7)	0.92 (23.4)
SS-TMT-FL5-NS4-	5/16	1/4	1.17 (29.7)	0.64 (16.3)	0.25 (6.4)	0.63 (15.9)	1.01 (25.7)
SS-TMT-FL6-NS4-	3/8	1/4	1.20 (30.5)	0.66 (16.8)	0.28 (7.1)	0.63 (15.9)	1.00 (25.4)
SS-TMT-FL6-NS6-	3/8	3/8	1.31 (33.3)	0.66 (16.8)	0.28 (7.1)	0.81 (20.6)	1.11 (28.2)

Metric Tube			NPT Thread				
Basic Ordering Number	T-Tube O.D. (mm)	P-NPT Size	Dimensions, mm (in.)				
			L	C	E (min.)	F	Lx
SS-TMT-ML6-NS4-	6	1/4	27.0 (1.06)	15.3 (0.60)	4.8 (0.19)	12.7 (0.50)	23.4 (0.92)
SS-TMT-ML8-NS4-	8	1/4	29.9 (1.18)	16.2 (0.64)	6.4 (0.25)	15.9 (0.63)	25.4 (1.00)
SS-TMT-ML10-NS4-	10	1/4	33.5 (1.32)	17.2 (0.68)	7.1 (0.28)	20.6 (0.81)	28.2 (1.11)
SS-TMT-ML10-NS8-	10	1/2	33.5 (1.32)	17.2 (0.68)	7.9 (0.31)	20.6 (0.81)	33.0 (1.30)
SS-TMT-ML12-NS4-	12	1/4	36.0 (1.42)	22.8 (0.90)	7.1 (0.28)	20.6 (0.81)	28.2 (1.11)
SS-TMT-ML12-NS6-	12	3/8	36.0 (1.42)	22.8 (0.90)	9.5 (0.37)	20.6 (0.81)	28.2 (1.11)
SS-TMT-ML12-NS8-	12	1/2	36.0 (1.42)	22.8 (0.90)	9.5 (0.37)	20.6 (0.81)	33.0 (1.30)

Female Branch Tees

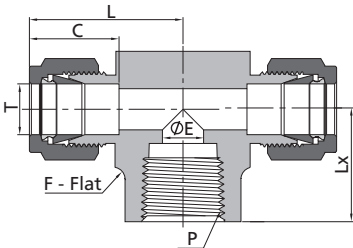

Fractional Tube			NPT Thread				
Basic Ordering Number	T-Tube O.D. (in.)	P-NPT Size	Dimensions, in. (mm)				
			L	C	E	F	Lx
SS-TTF-FL4-NS4-	1/4	1/4	1.17 (29.7)	0.60 (15.2)	0.19 (4.8)	0.69 (17.5)	0.88 (22.4)
SS-TTF-FL6-NS4-	3/8	1/4	1.23 (31.2)	0.66 (16.8)	0.28 (7.1)	0.69 (17.5)	0.88 (22.4)
SS-TTF-FL6-NS6-	3/8	3/8	1.31 (33.3)	0.66 (16.8)	0.28 (7.1)	0.81 (20.6)	0.88 (22.4)

Metric Tube			NPT Thread				
Basic Ordering Number	T-Tube O.D. (mm)	P-NPT Size	Dimensions, mm (in.)				
			L	C	E	F	Lx
SS-TTF-ML6-NS4-	6	1/4	29.8 (1.17)	15.3 (0.60)	4.8 (0.19)	17.5 (0.69)	22.4 (0.88)
SS-TTF-ML8-NS4-	8	1/4	30.6 (1.20)	16.2 (0.64)	6.4 (0.25)	17.5 (0.69)	22.4 (0.88)
SS-TTF-ML10-NS4-	10	1/4	33.5 (1.32)	17.2 (0.68)	7.9 (0.31)	20.6 (0.81)	22.4 (0.88)
SS-TTF-ML12-NS4-	12	1/4	36.0 (1.42)	22.8 (0.90)	9.5 (0.37)	20.6 (0.81)	22.4 (0.88)
SS-TTF-ML12-NS6-	12	3/8	36.0 (1.42)	22.8 (0.90)	9.5 (0.37)	20.6 (0.81)	22.4 (0.88)
SS-TTF-ML12-NS8-	12	1/2	38.8 (1.53)	22.8 (0.90)	9.5 (0.37)	25.4 (1.00)	28.5 (1.12)

Female Run Tees

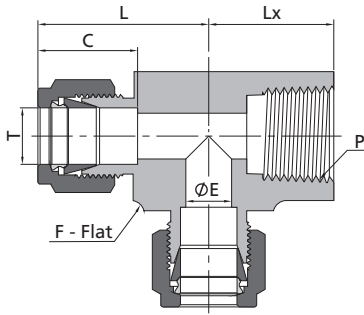

Fractional Tube			NPT Thread				
Basic Ordering Number	T-Tube O.D. (in.)	P-NPT Size	Dimensions, in. (mm)				
			L	C	E	F	Lx
SS-TFT-FL4-NS4-	1/4	1/4	1.17 (29.7)	0.60 (15.2)	0.19 (4.8)	0.69 (17.5)	0.88 (22.4)
SS-TFT-FL6-NS4-	3/8	1/4	1.23 (31.2)	0.66 (16.8)	0.28 (7.1)	0.69 (17.5)	0.88 (22.4)

Metric Tube			NPT Thread				
Basic Ordering Number	T-Tube O.D. (mm)	P-NPT Size	Dimensions, mm (in.)				
			L	C	E	F	Lx
SS-TFT-ML6-NS4-	6	1/4	29.8 (1.17)	15.3 (0.60)	4.8 (0.19)	17.5 (0.69)	22.4 (0.88)
SS-TFT-ML8-NS4-	8	1/4	30.6 (1.20)	16.2 (0.64)	6.4 (0.25)	17.5 (0.69)	22.4 (0.88)
SS-TFT-ML10-NS4-	10	1/4	33.5 (1.32)	17.2 (0.68)	7.9 (0.31)	20.6 (0.81)	22.4 (0.88)
SS-TFT-ML12-NS4-	12	1/4	36.0 (1.42)	22.8 (0.90)	9.5 (0.37)	20.6 (0.81)	22.4 (0.88)
SS-TFT-ML12-NS6-	12	3/8	36.0 (1.42)	22.8 (0.90)	9.5 (0.37)	20.6 (0.81)	23.1 (0.91)
SS-TFT-ML12-NS8-	12	1/2	38.8 (1.53)	22.8 (0.90)	9.5 (0.37)	25.4 (1.00)	28.5 (1.12)

Union Crosses

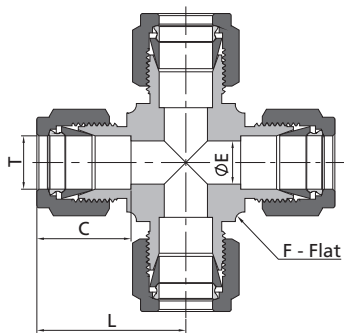

Fractional Tube		NPT Thread			
Basic Ordering Number	T-Tube O.D. (in.)	Dimensions, in. (mm)			
		L	C	E	F
SS-C-FL4-	1/4	1.06 (26.9)	0.60 (15.2)	0.19 (4.8)	0.50 (12.7)
SS-C-FL5-	5/16	1.17 (29.7)	0.64 (16.2)	0.25 (6.4)	0.63 (15.9)
SS-C-FL6-	3/8	1.20 (30.5)	0.66 (16.8)	0.28 (7.1)	0.63 (15.9)
SS-C-FL8-	1/2	1.42 (36.1)	0.90 (22.9)	0.41 (10.4)	0.81 (20.6)

Metric Tube		NPT Thread			
Basic Ordering Number	T-Tube O.D. (mm)	Dimensions, mm (in.)			
		L	C	E	F
SS-C-ML6-	6	27.0 (1.06)	15.3 (0.60)	4.8 (0.19)	12.7 (0.50)
SS-C-ML8-	8	29.9 (1.18)	16.2 (0.64)	6.4 (0.25)	15.9 (0.63)
SS-C-ML10-	10	33.5 (1.32)	17.2 (0.68)	7.9 (0.31)	20.6 (0.81)
SS-C-ML12-	12	36.0 (1.42)	22.8 (0.90)	9.5 (0.37)	20.6 (0.81)
SS-C-ML16-	16	37.0 (1.46)	24.4 (0.96)	12.7 (0.50)	23.8 (0.94)

6P Series Pipe Fittings

Features

- FITOK's enhanced-316/316L stainless steel is available upon request for better hydrogen embrittlement resistance
- Higher manufacturing and inspection standards
- Low-temperature fluorocarbon O-ring complies with EC79 standards
- Thread rolling process on male thread provides higher strength and hardness

Technical Data

Body Material	316 SS
Working Temperature	NPT: -325~400 °F (-198~204 °C) SAE/MS: -40~392 °F (-40~200 °C)
Thread Specification	NPT: ASME B1.20.1, SAE AS71051 SAE/MS: ASME B1.1, SAE J475

Ordering Information and Dimensions

Products not listed in this catalog may also be suitable for hydrogen applications, please contact FITOK Group or an authorized FITOK distributor.

Hex Nipples

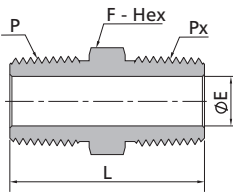

Male NPT Thread

Ordering Number	P-NPT Size	Px-NPT Size	Dimensions, in. (mm)			Working Pressure psig (bar)
			L	E	F	
SS-PHN-NS4-H2	1/4	1/4	1.40 (35.6)	0.28 (7.1)	0.56 (14.3)	8000 (551)
SS-PHN-NS6-H2	3/8	3/8	1.43 (36.3)	0.38 (9.7)	0.69 (17.5)	7800 (537)

Hex Nipples

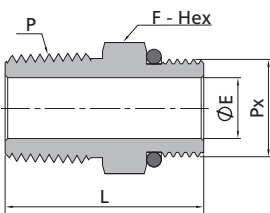

Male NPT Thread

Male SAE/MS Straight Thread

Ordering Number	P-NPT Size	Px-SAE Nominal Size	Px-SAE/MS Thread Specification	Dimensions, in. (mm)			Working Pressure psig (bar)
				L	E	F	
SS-PHN-NS4-ST7-H2	1/4	4	7/16-20	1.20 (30.5)	0.20 (5.1)	0.56 (14.3)	5075 (350)
SS-PHN-NS6-ST9-H2	3/8	6	9/16-18	1.26 (32.0)	0.28 (7.1)	0.69 (17.5)	5075 (350)

Adapters

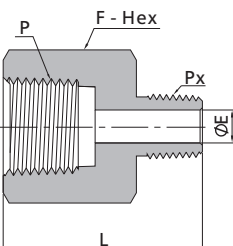

Female NPT Thread

Male NPT Thread

Ordering Number	P-NPT Size	Px-NPT Size	Dimensions, in. (mm)			Working Pressure psig (bar)
			L	E	F	
SS-PA-NS4-H2	1/4	1/4	1.40 (35.6)	0.28 (7.1)	0.75 (19.1)	6600 (454)
SS-PA-NS6-NS4-H2	3/8	1/4	1.50 (38.1)	0.28 (7.1)	0.87 (22.2)	5300 (365)

Adapters

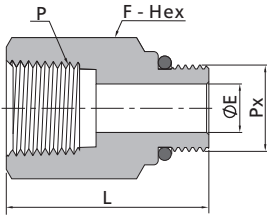

Female NPT Thread				Male SAE/MS Straight Thread			
Ordering Number	P-NPT Size	Px-SAE Nominal Size	Px-SAE/MS Thread Specification	Dimensions, in. (mm)			Working Pressure psig (bar)
				L	E	F	
SS-PA-NS4-ST7-H2	1/4	4	7/16-20	1.32 (33.5)	0.20 (5.1)	0.75 (19.1)	5075 (350)

Reducing Bushings

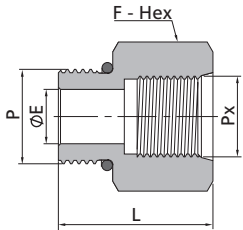

Male SAE/MS Straight Thread					Female SAE/MS Straight Thread			
Ordering Number	P-SAE Nominal Size	P-SAE/MS Thread Specification	Px-SAE Nominal Size	Px-SAE/MS Thread Specification	Dimensions, in. (mm)			Working Pressure psig (bar)
					L	E	F	
SS-PRB-ST9-US7-H2	6	9/16-18	4	7/16-20	1.12 (28.4)	0.28 (7.1)	0.81 (20.6)	5075 (350)
SS-PRB-SH12-US7-H2	8	3/4-16	4	7/16-20	0.98 (24.9)	0.39 (9.9)	0.87 (22.2)	5075 (350)
SS-PRB-SH12-US9-H2	8	3/4-16	6	9/16-18	1.19 (30.2)	0.42 (10.7)	1.00 (25.4)	5075 (350)

Hex Couplings

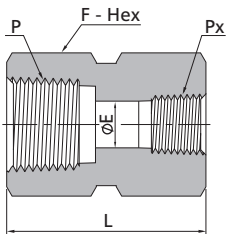

Female NPT Thread						
Ordering Number	P-NPT Size	Px-NPT Size	Dimensions, in. (mm)			Working Pressure psig (bar)
			L	E	F	
SS-PCG-NS4-H2	1/4	1/4	1.19 (30.2)	0.45 (11.4)	0.75 (19.1)	6600 (454)
SS-PCG-NS6-NS4-H2	3/8	1/4	1.38 (35.1)	0.45 (11.4)	0.87 (22.2)	5300 (365)
SS-PCG-NS6-H2	3/8	3/8	1.31 (33.3)	0.59 (15.0)	0.87 (22.2)	5300 (365)

Pipe Plugs

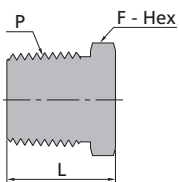

Male NPT Thread			
Ordering Number	P-NPT Size	Dimensions, in. (mm)	
		L	F
SS-PP-NS4-H2	1/4	0.75 (19.1)	0.56 (14.3)
SS-PP-NS6-H2	3/8	0.78 (19.8)	0.69 (17.5)

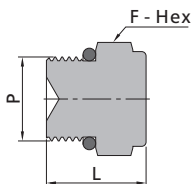

Male SAE/MS Straight Thread				
Ordering Number	P-SAE Nominal Size	P-SAE/MS Thread Specification	Dimensions, in. (mm)	
			L	F
SS-PP-ST6-H2	3	3/8-24	0.61 (15.5)	0.50 (12.7)
SS-PP-ST7-H2	4	7/16-20	0.76 (19.3)	0.56 (14.3)
SS-PP-ST9-H2	5	1/2-20	0.71 (18.1)	0.63 (15.9)
SS-PP-ST9-H2	6	9/16-18	0.82 (20.8)	0.69 (17.5)
SS-PP-SH12-H2	8	3/4-16	0.89 (22.6)	0.87 (22.2)

Hollow Hex Plugs

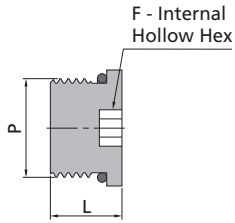

Male SAE/MS Straight Thread				
Ordering Number	P-SAE Nominal Size	P-SAE/MS Thread Specification	Dimensions, in. (mm)	
			L	F
SS-PI-ST6-H2	3	3/8-24	0.38 (9.7)	0.16 (4.0)
SS-PI-ST7-H2	4	7/16-20	0.45 (11.4)	0.19 (4.8)
SS-PI-ST9-H2	6	9/16-18	0.48 (12.2)	0.25 (6.4)
SS-PI-SH12-H2	8	3/4-16	0.56 (14.2)	0.31 (7.9)

Pipe Caps

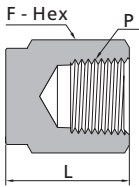

Female NPT Thread				
Ordering Number	P-NPT Size	Dimensions, in. (mm)		Working Pressure psig (bar)
		L	F	
SS-PC-NS4-H2	1/4	0.91 (23.1)	0.75 (19.1)	6600 (454)
SS-PC-NS6-H2	3/8	1.03 (26.2)	0.87 (22.2)	5300 (365)
SS-PC-NS8-H2	1/2	1.34 (34.0)	1.06 (27.0)	4900 (337)

Street Elbows

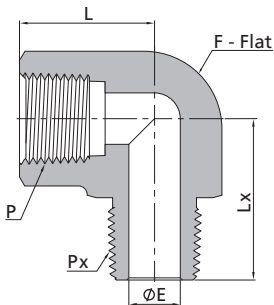

Female NPT Thread				Male NPT Thread			
Ordering Number	P-NPT Size	Px-NPT Size	Dimensions, in. (mm)				Working Pressure psig (bar)
			L	E	F	Lx	
SS-PSE-NS4-NS6-H2	1/4	3/8	1.17 (29.7)	0.34 (8.6)	0.69 (17.5)	1.17 (29.7)	7200 (496)

20D Series Tube Fittings

Features

- ◎ FITOK's enhanced-316/316L stainless steel is available upon request for better hydrogen embrittlement resistance
- ◎ Compatible with any ASTM A269 tubing. For the highest level of performance, use with FITOK T15 and T20D series tubing
- ◎ Long tube-support area provides better vibration resistance
- ◎ EC79 approval for 70 MPa hydrogen system applications

Technical Data

Body Material	High tensile 316 SS
Max. Working Pressure	Tube: 20000 psig (1379 bar) NPT: 15000 psig (1034 bar)
Working Temperature	Tube: -325~800 °F (-198~427 °C) NPT: -325~400 °F (-198~204 °C)

Ordering Information and Marking

To order a fitting with EC79 certification for hydrogen-powered vehicles, add **-EC79** at the end of the standard part number. The marking on the fitting is shown as below:

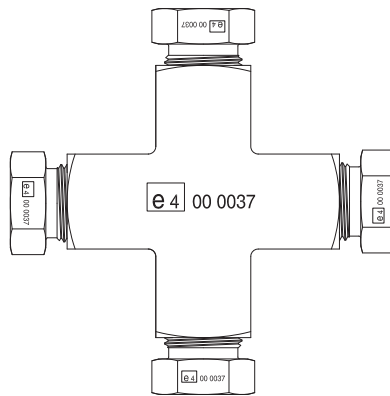

Marking on EC79 Certified Tube Fittings

To order a fitting that does not require EC79 certification for hydrogen systems, add **-H2** at the end of the standard part number. The marking on the fitting is the same as FITOK standard tube fitting. The full part number is labelled on the box.

Products not listed in this catalog may also be suitable for hydrogen applications, please contact FITOK Group or an authorized FITOK distributor.

Unions

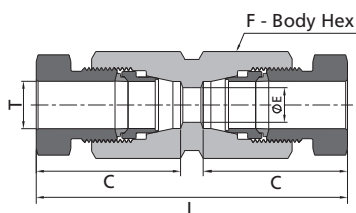

Tube		Dimensions, in. (mm)			
Basic Ordering Number	T-Tube O.D. in.	L	C	E	F
		SS-DU-DFF4-	1/4	3.00 (76.2)	1.38 (35.2)
SS-DU-DFF6-	3/8	3.07 (77.9)	1.42 (36.1)	0.25 (6.4)	0.75 (19.1)
SS-DU-DFF8-	1/2	3.36 (85.4)	1.56 (39.6)	0.37 (9.5)	1.00 (25.4)

Male Connectors

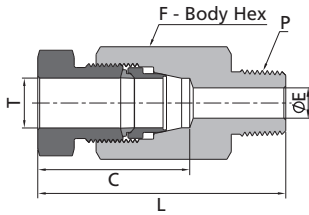

Tube	Basic Ordering Number	T-Tube O.D. in.	P-NPT Size	NPT Thread			
				Dimensions, in. (mm)			
				L	C	E	F
SS-DCM-DFF4-NS4-		1/4	1/4	2.08 (52.8)	1.39 (35.2)	0.19 (4.8)	0.63 (15.9)
SS-DCM-DFF4-NS6-		1/4	3/8	2.08 (52.8)	1.39 (35.2)	0.19 (4.8)	0.69 (17.5)
SS-DCM-DFF4-NS8-		1/4	1/2	2.32 (59.0)	1.39 (35.2)	0.19 (4.8)	0.87 (22.2)
SS-DCM-DFF6-NS4-		3/8	1/4	2.17 (55.1)	1.42 (36.1)	0.25 (6.4)	0.75 (19.1)
SS-DCM-DFF6-NS6-		3/8	3/8	2.17 (55.1)	1.42 (36.1)	0.25 (6.4)	0.75 (19.1)
SS-DCM-DFF6-NS8-		3/8	1/2	2.30 (58.3)	1.42 (36.1)	0.25 (6.4)	0.87 (22.2)
SS-DCM-DFF8-NS4-		1/2	1/4	2.53 (64.3)	1.56 (39.6)	0.25 (6.4)	1.00 (25.4)
SS-DCM-DFF8-NS6-		1/2	3/8	2.53 (64.3)	1.56 (39.6)	0.31 (7.9)	1.00 (25.4)
SS-DCM-DFF8-NS8-		1/2	1/2	2.65 (67.4)	1.56 (39.6)	0.37 (9.5)	1.00 (25.4)

Female Connectors

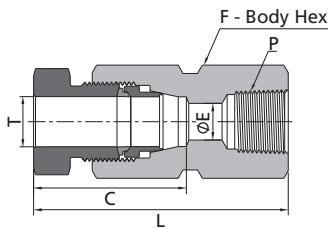

Tube	Basic Ordering Number	T-Tube O.D. in.	P-NPT Size	NPT Thread			
				Dimensions, in. (mm)			
				L	C	E	F
SS-DCF-DFF4-FNS4-		1/4	1/4	2.33 (59.1)	1.38 (35.2)	0.19 (4.8)	0.94 (23.8)
SS-DCF-DFF6-FNS4-		3/8	1/4	2.29 (58.1)	1.42 (36.1)	0.25 (6.4)	0.94 (23.8)
SS-DCF-DFF8-FNS4-		1/2	1/4	2.78 (70.6)	1.56 (39.6)	0.37 (9.5)	1.00 (25.4)
SS-DCF-DFF8-FNS8-		1/2	1/2	3.03 (77.0)	1.56 (39.6)	0.37 (9.5)	1.38 (34.9)

Union Elbows

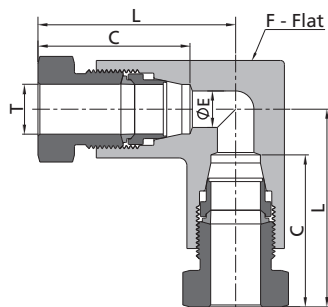

Tube	Basic Ordering Number	T-Tube O.D. in.	NPT Thread			
			Dimensions, in. (mm)			
			L	C	E	F
SS-DLU-DFF4-		1/4	1.70 (43.1)	1.38 (35.2)	0.19 (4.8)	0.63 (15.9)
SS-DLU-DFF6-		3/8	1.67 (42.4)	1.42 (36.1)	0.25 (6.4)	0.75 (19.1)
SS-DLU-DFF8-		1/2	2.03 (51.6)	1.56 (39.6)	0.37 (9.5)	1.00 (25.4)

Male Elbows

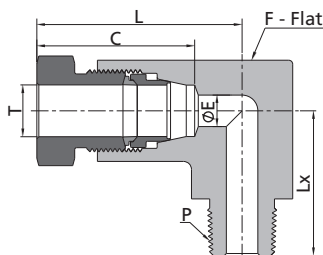

Tube	Basic Ordering Number	T-Tube O.D. in.	P-NPT Size	NPT Thread				
				Dimensions, in. (mm)				
				L	Lx	C	E	F
SS-DLM-DFF4-NS4-		1/4	1/4	1.70 (43.1)	0.94 (23.8)	1.38 (35.2)	0.19 (4.8)	0.63 (15.9)
SS-DLM-DFF4-NS6-		1/4	3/8	1.70 (43.1)	1.00 (25.4)	1.38 (35.2)	0.19 (4.8)	0.75 (19.1)
SS-DLM-DFF4-NS8-		1/4	1/2	1.70 (43.1)	1.38 (34.9)	1.38 (35.2)	0.19 (4.8)	1.00 (25.4)
SS-DLM-DFF6-NS4-		3/8	1/4	1.67 (42.4)	1.00 (25.4)	1.42 (36.1)	0.25 (6.4)	0.75 (19.1)
SS-DLM-DFF6-NS6-		3/8	3/8	1.67 (42.4)	1.06 (27.0)	1.42 (36.1)	0.25 (6.4)	0.75 (19.1)
SS-DLM-DFF6-NS8-		3/8	1/2	1.67 (42.4)	1.38 (34.9)	1.42 (36.1)	0.25 (6.4)	1.00 (25.4)
SS-DLM-DFF8-NS4-		1/2	1/4	2.03 (51.6)	1.19 (30.2)	1.56 (39.6)	0.25 (6.4)	1.00 (25.4)
SS-DLM-DFF8-NS6-		1/2	3/8	2.03 (51.6)	1.19 (30.2)	1.56 (39.6)	0.31 (7.9)	1.00 (25.4)
SS-DLM-DFF8-NS8-		1/2	1/2	2.03 (51.6)	1.38 (34.9)	1.56 (39.6)	0.37 (9.5)	1.00 (25.4)

Union Tees

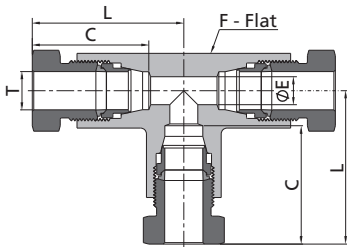

Tube		Dimensions, in. (mm)			
Basic Ordering Number	T-Tube O.D. in.	L	C	E	F
		SS-DT-DFF4-	1/4	1.70 (43.1)	1.38 (35.2)
SS-DT-DFF6-	3/8	1.67 (42.4)	1.42 (36.1)	0.25 (6.4)	0.75 (19.1)
SS-DT-DFF8-	1/2	2.03 (51.6)	1.56 (39.6)	0.37 (9.5)	1.00 (25.4)

Male Branch Tees

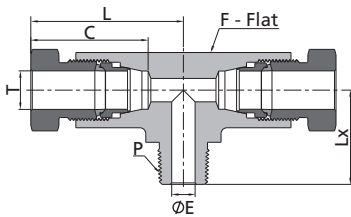

Tube				NPT Thread				
Basic Ordering Number	T-Tube O.D. in.	P-NPT Size	Dimensions, in. (mm)					
			L	Lx	C	E	F	
SS-DT-DFF4-DFF4-NS4-	1/4	1/4	1.70 (43.1)	1.00 (25.4)	1.38 (35.2)	0.19 (4.8)	0.63 (15.9)	
SS-DT-DFF6-DFF6-NS4-	3/8	1/4	1.67 (42.4)	1.06 (27.0)	1.42 (36.1)	0.25 (6.4)	0.75 (19.1)	
SS-DT-DFF8-DFF8-NS4-	1/2	1/4	2.03 (51.6)	1.19 (30.2)	1.56 (39.6)	0.25 (6.4)	1.00 (25.4)	
SS-DT-DFF8-DFF8-NS6-	1/2	3/8	2.03 (51.6)	1.19 (30.2)	1.56 (39.6)	0.31 (7.9)	1.00 (25.4)	

Union Crosses

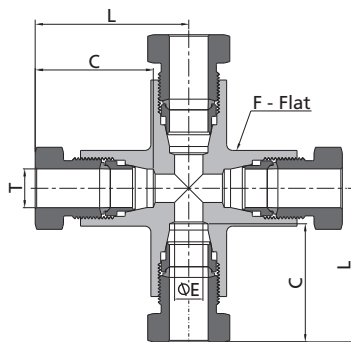

Tube		Dimensions, in. (mm)			
Basic Ordering Number	T-Tube O.D. in.	L	C	E	F
		SS-DX-DFF4-	1/4	1.70 (43.1)	1.38 (35.2)
SS-DX-DFF6-	3/8	1.67 (42.4)	1.42 (36.1)	0.25 (6.4)	0.75 (19.1)
SS-DX-DFF8-	1/2	2.03 (51.6)	1.56 (39.6)	0.37 (9.5)	1.00 (25.4)

Reducers

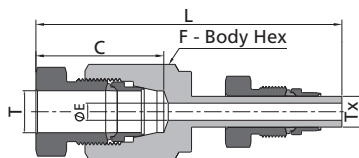

Tube			Dimensions, in. (mm)			
Basic Ordering Number	T-Tube O.D. in.	Tx-Tube O.D. in.	L	C	E	F
			SS-DR-DFF4-DFT6-	1/4	3/8	3.20 (82.1)
SS-DR-DFF6-DFT8-	3/8	1/2	3.43 (87.1)	1.42 (36.1)	0.25 (6.4)	0.75 (19.1)
SS-DR-DFF8-DFT6-	1/2	3/8	3.53 (89.7)	1.56 (39.6)	0.21 (5.3)	1.00 (25.4)

The right ends of reducers will be preassembled with ferrules before ex-work.

Port Connectors

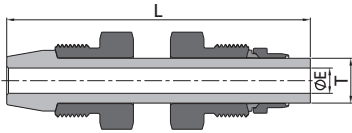

Tube			
Basic Ordering Number	T-Tube O.D. in.	Dimensions, in. (mm)	
		L	E
SS-DP-DFF4-	1/4	2.66 (67.5)	0.12 (3.0)
SS-DP-DFF6-	3/8	2.72 (69.0)	0.21 (5.3)
SS-DP-DFF8-	1/2	3.04 (77.3)	0.28 (7.1)

The ferrules and nuts are included and pre-assembled before ex-work.

Adapters

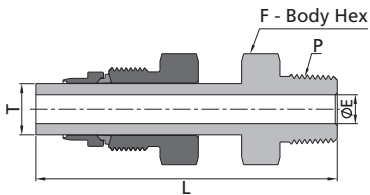

Tube			NPT Thread		
Basic Ordering Number	T-Tube O.D. in.	P-NPT Size	Dimensions, in. (mm)		
			L	E	F
SS-DAM-DFT4-NS4-	1/4	1/4	2.30 (58.5)	0.12 (3.0)	0.56 (14.3)
SS-DAM-DFT6-NS4-	3/8	1/4	2.38 (60.4)	0.21 (5.3)	0.56 (14.3)
SS-DAM-DFT6-NS8-	3/8	1/2	2.67 (67.9)	0.21 (5.3)	0.87 (22.2)
SS-DAM-DFT8-NS4-	1/2	1/4	2.55 (64.8)	0.25 (6.4)	0.56 (14.3)
SS-DAM-DFT8-NS8-	1/2	1/2	2.84 (72.2)	0.28 (7.1)	0.87 (22.2)

The ferrules and nuts are included and pre-assembled before ex-work.

Plugs

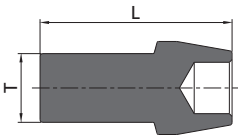

Tube		
Basic Ordering Number	T-Tube O.D. in.	Dimensions, in. (mm)
		L
SS-TP-DFF4-	1/4	1.20 (30.4)
SS-TP-DFF6-	3/8	1.19 (30.2)
SS-TP-DFF8-	1/2	1.36 (34.6)

When using a plug, ferrules are not required.

Caps

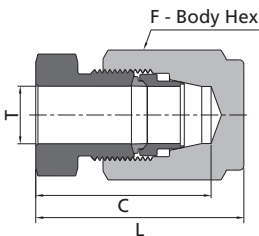

Tube				
Basic Ordering Number	T-Tube O.D. in.	Dimensions, in. (mm)		
		L	C	F
SS-DTC-DFF4-	1/4	1.70 (43.1)	1.38 (35.2)	0.63 (15.9)
SS-DTC-DFF6-	3/8	1.76 (44.8)	1.42 (36.1)	0.75 (19.1)
SS-DTC-DFF8-	1/2	1.85 (47.0)	1.56 (39.6)	1.00 (25.4)

20M Series Medium Pressure Fittings

Features

- © FITOK's enhanced-316/316L stainless steel is available upon request for better hydrogen embrittlement resistance
- © Higher manufacturing and inspection standards
- © Cone and thread (C&T) connection with any medium pressure tubing. The best match is with FITOK T20M series tubing

Technical Data

Body Material	High tensile 316 SS
Max. Working Pressure	20000 psig (1379 bar)
Working Temperature	-423~1200 °F (-252~649 °C)

Ordering Information and Dimensions

Products not listed in this catalog may also be suitable for hydrogen applications, please contact FITOK Group or an authorized FITOK distributor.

Unions

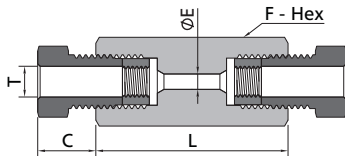

Tube		Dimensions, in. (mm)				
Ordering Number	T-Tube O.D. in.	Dimensions, in. (mm)				
		L	C	E	F	
SS-MU-MF4-H2	1/4	1.62 (41.1)	0.38 (9.7)	0.11 (2.8)	0.63 (15.9)	
SS-MU-MF6-H2	3/8	1.75 (44.5)	0.44 (11.2)	0.20 (5.1)	0.75 (19.1)	
SS-MU-MF9-H2	9/16	2.14 (54.3)	0.55 (14.0)	0.31 (7.9)	1.00 (25.4)	

Union Elbows

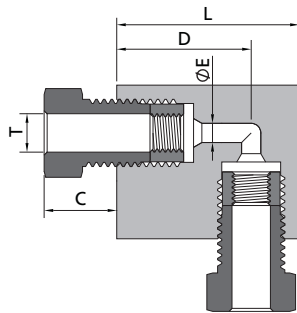

Tube		Dimensions, in. (mm)				
Ordering Number	T-Tube O.D. in.	Dimensions, in. (mm)				
		C	D	L	E	Thickness
SS-MLU-MF4-H2	1/4	0.38 (9.7)	0.75 (19.1)	1.12 (28.4)	0.11 (2.8)	0.63 (15.9)
SS-MLU-MF6-H2	3/8	0.44 (11.2)	1.00 (25.4)	1.38 (34.9)	0.20 (5.1)	0.75 (19.1)
SS-MLU-MF9-H2	9/16	0.55 (14.0)	1.25 (31.8)	1.75 (44.5)	0.31 (7.9)	1.00 (25.4)

Union Tees

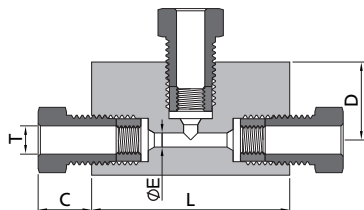

Tube		Dimensions, in. (mm)				
Ordering Number	T-Tube O.D. in.	Dimensions, in. (mm)				
		C	D	L	E	Thickness
SS-MT-MF4-H2	1/4	0.38 (9.7)	0.75 (19.1)	1.50 (38.1)	0.11 (2.8)	0.63 (15.9)
SS-MT-MF6-H2	3/8	0.44 (11.2)	1.00 (25.4)	2.00 (50.8)	0.20 (5.1)	0.75 (19.1)
SS-MT-MF9-H2	9/16	0.55 (14.0)	1.25 (31.8)	2.50 (63.5)	0.31 (7.9)	1.00 (25.4)

Union Crosses

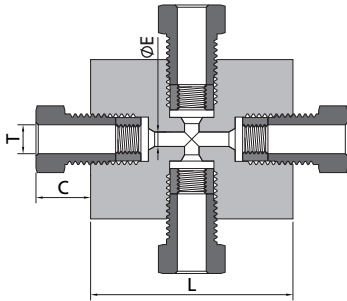

Tube		Dimensions, in. (mm)			
Ordering Number	T-Tube O.D. in.	C	E	L	Thickness
SS-MX-MF6-H2	3/8	0.44 (11.2)	0.20 (5.1)	2.00 (50.8)	0.75 (19.1)
SS-MX-MF9-H2	9/16	0.55 (14.0)	0.31 (7.9)	2.50 (63.5)	1.00 (25.4)

Plugs

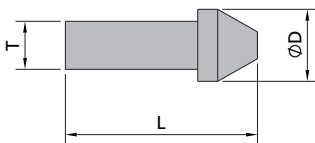

Tube		Dimensions, in. (mm)	
Ordering Number	T-Tube O.D. in.	D	L
		SS-MTP-MF4-H2	1/4
SS-MTP-MF6-H2	3/8	0.47 (11.9)	1.18 (30.0)
SS-MTP-MF9-H2	9/16	0.72 (18.3)	1.40 (35.6)

When using a plug, collar is not required.

Caps

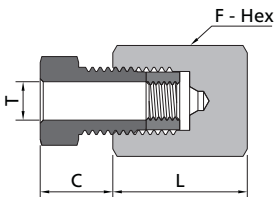

Tube		Dimensions, in. (mm)		
Ordering Number	T-Tube O.D. in.	L	C	F
		SS-MTC-MF4-H2	1/4	0.81 (20.6)
SS-MTC-MF6-H2	3/8	1.13 (28.6)	0.44 (11.2)	0.75 (19.1)
SS-MTC-MF9-H2	9/16	1.38 (34.9)	0.55 (14.0)	1.00 (25.4)

PMH Series Pipe Fittings

Features

- ◎ FITOK's enhanced-316/316L stainless steel is available upon request for better hydrogen embrittlement resistance
- ◎ Higher manufacturing and inspection standards
- ◎ Thread rolling process on male thread provides higher strength and hardness
- ◎ Higher working pressures on standard pipe fitting sizes

Technical Data

Body Material	High tensile 316 SS
Max. Working Pressure	15000 psig (1034 bar)
Working Temperature	-325~400 °F (-198~204 °C)

Ordering Information and Dimensions

Products not listed in this catalog may also be suitable for hydrogen applications, please contact FITOK Group or an authorized FITOK distributor.

Hex Nipples

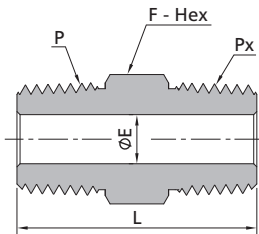

Male NPT Thread			Dimensions, in. (mm)		
Ordering Number	P-NPT Size	Px-NPT Size	L	F	E
			SS-HPN-NS4-H2	1/4	1/4
SS-HPN-NS6-H2	3/8	3/8	1.52 (38.6)	0.69 (17.5)	0.31 (7.9)
SS-HPN-NS8-H2	1/2	1/2	1.95 (49.6)	0.87 (22.2)	0.38 (9.6)

Pipe Caps

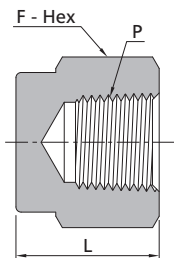

Female NPT Thread		Dimensions, in. (mm)	
Ordering Number	P-NPT Size	L	F
		SS-HPC-FNS4-H2	1/4
SS-HPC-FNS6-H2	3/8	1.03 (26.2)	1.13 (28.6)
SS-HPC-FNS8-H2	1/2	1.34 (34.0)	1.37 (34.9)

Pipe Plugs

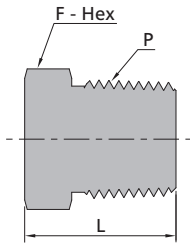

Male NPT Thread			
Ordering Number	P-NPT Size	Dimensions, in. (mm)	
		L	F
SS-HPP-NS4-H2	1/4	0.87 (22.2)	0.56 (14.3)
SS-HPP-NS6-H2	3/8	0.93 (23.6)	0.69 (17.5)
SS-HPP-NS8-H2	1/2	1.16 (29.5)	0.87 (22.2)

Hex Couplings

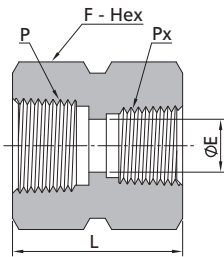

Female NPT Thread					
Ordering Number	P-NPT Size	Px-NPT Size	Dimensions, in. (mm)		
			L	E	F
SS-HPG-FNS4-H2	1/4	1/4	1.32 (33.5)	0.41 (10.4)	0.94 (23.8)
SS-HPG-FNS6-H2	3/8	3/8	1.32 (33.5)	0.54 (13.8)	1.13 (28.6)
SS-HPG-FNS8-H2	1/2	1/2	1.72 (43.8)	0.67 (17.0)	1.37 (34.9)

Adapters

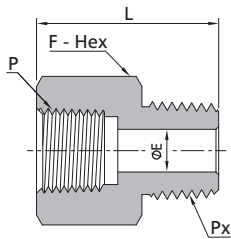

Female NPT Thread			Male NPT Thread		
Ordering Number	P-NPT Size	Px-NPT Size	Dimensions, in. (mm)		
			L	E	F
SS-HPA-FNS4-NS4-H2	1/4	1/4	1.37 (34.9)	0.25 (6.4)	0.94 (23.8)
SS-HPA-FNS4-NS6-H2	1/4	3/8	1.37 (34.9)	0.31 (7.9)	0.94 (23.8)
SS-HPA-FNS6-NS4-H2	3/8	1/4	1.42 (36.0)	0.25 (6.4)	1.13 (28.6)
SS-HPA-FNS6-NS6-H2	3/8	3/8	1.42 (36.0)	0.31 (7.9)	1.13 (28.6)
SS-HPA-FNS6-NS8-H2	3/8	1/2	1.61 (41.0)	0.38 (9.6)	1.13 (28.6)
SS-HPA-FNS8-NS6-H2	1/2	3/8	1.72 (43.1)	0.31 (7.9)	1.37 (34.9)
SS-HPA-FNS8-NS8-H2	1/2	1/2	1.89 (48.0)	0.38 (9.6)	1.37 (34.9)

Street Elbows

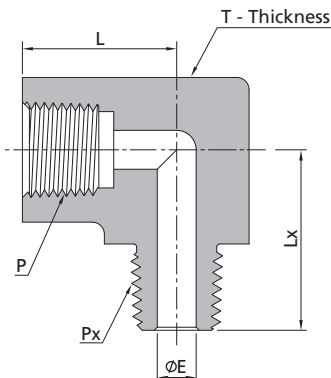

Female NPT Thread			Male NPT Thread			
Ordering Number	P-NPT Size	Px-NPT Size	Dimensions, in. (mm)			
			L	E	Lx	T
SS-HPE-FNS4-NS4-H2	1/4	1/4	1.00 (25.4)	0.25 (6.4)	1.06 (27.0)	0.75 (19.1)
SS-HPE-FNS4-NS6-H2	1/4	3/8	1.00 (25.4)	0.31 (7.9)	1.06 (27.0)	0.75 (19.1)
SS-HPE-FNS6-NS6-H2	3/8	3/8	1.20 (30.6)	0.31 (7.9)	1.20 (30.6)	1.00 (25.4)
SS-HPE-FNS6-NS8-H2	3/8	1/2	1.20 (30.6)	0.38 (9.6)	1.38 (35.0)	1.00 (25.4)
SS-HPE-FNS8-NS8-H2	1/2	1/2	1.50 (38.1)	0.38 (9.6)	1.61 (40.8)	1.37 (34.9)

AMH Series Adapter Fittings

Feature

- © FITOK's enhanced-316/316L stainless steel is available upon request for better hydrogen embrittlement resistance
- © Higher manufacturing and inspection standards

Technical Data

Body Material	High tensile 316 SS
Max. Working Pressure	NPT: 15000 psig (1034 bar) Tube: 20000 psig (1379 bar)
Working Temperature	NPT: -325~400 °F (-198~204 °C) Tube: -325~800 °F (-198~427 °C)

Ordering Information and Dimensions

Products not listed in this catalog may also be suitable for hydrogen applications, please contact FITOK Group or an authorized FITOK distributor.

20M Series Medium Pressure Fittings to 20D Series Tube Fittings

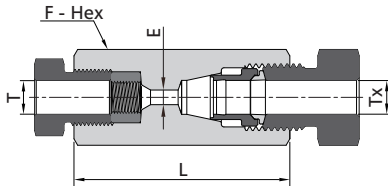

Ordering Number	20M Series Medium Pressure Fittings		20D Series Tube Fittings		
	T-Tube O.D. in.	Tx-Tube O.D. in.	Dimensions, in. (mm)		
	L	E	F		
SS-FFC-MF4-DFF4-H2	1/4	1/4	1.67 (42.3)	0.11 (2.8)	0.63 (15.9)
SS-FFC-MF4-DFF6-H2	1/4	3/8	1.76 (44.7)	0.11 (2.8)	0.75 (19.1)
SS-FFC-MF6-DFF4-H2	3/8	1/4	1.85 (47.1)	0.19 (4.8)	0.75 (19.1)
SS-FFC-MF6-DFF6-H2	3/8	3/8	1.89 (47.9)	0.20 (5.2)	0.75 (19.1)
SS-FFC-MF6-DFF8-H2	3/8	1/2	2.06 (52.2)	0.20 (5.2)	1.00 (25.4)
SS-FFC-MF9-DFF6-H2	9/16	3/8	2.07 (52.6)	0.25 (6.4)	1.00 (25.4)
SS-FFC-MF9-DFF8-H2	9/16	1/2	2.24 (57.0)	0.31 (7.9)	1.00 (25.4)

20M Series Medium Pressure Fittings to Female NPT

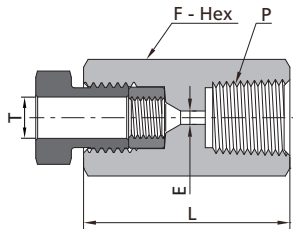

Ordering Number	20M Series Medium Pressure Fittings		Female NPT		
	T-Tube O.D. in.	P-NPT Size	Dimensions, in. (mm)		
	L	E	F		
SS-FFC-MF4-FNS4-H2	1/4	1/4	1.63 (41.3)	0.11 (2.8)	0.94 (23.8)
SS-FFC-MF4-FNS6-H2	1/4	3/8	1.63 (41.3)	0.11 (2.8)	1.13 (28.6)
SS-FFC-MF6-FNS4-H2	3/8	1/4	1.75 (44.5)	0.20 (5.1)	0.94 (23.8)
SS-FFC-MF6-FNS6-H2	3/8	3/8	1.81 (46.0)	0.20 (5.1)	1.13 (28.6)
SS-FFC-MF6-FNS8-H2	3/8	1/2	2.13 (54.0)	0.20 (5.1)	1.37 (34.9)
SS-FFC-MF9-FNS6-H2	9/16	3/8	2.00 (50.8)	0.31 (7.9)	1.13 (28.6)
SS-FFC-MF9-FNS8-H2	9/16	1/2	2.25 (57.2)	0.31 (7.9)	1.37 (34.9)

20M Series Medium Pressure Fittings to Male NPT

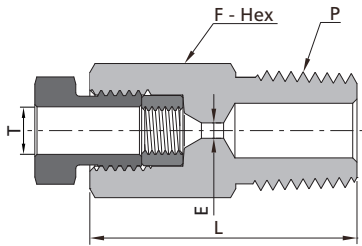

20M Series Medium Pressure Fittings			Male NPT		
Ordering Number	T-Tube O.D. in.	P-NPT Size	Dimensions, in. (mm)		
			L	E	F
SS-FMA-MF4-NS4-H2	1/4	1/4	1.37 (34.9)	0.11 (2.8)	0.63 (15.9)
SS-FMA-MF4-NS6-H2	1/4	3/8	1.37 (34.9)	0.11 (2.8)	0.69 (17.5)
SS-FMA-MF6-NS4-H2	3/8	1/4	1.50 (38.1)	0.20 (5.2)	0.75 (19.1)
SS-FMA-MF6-NS6-H2	3/8	3/8	1.50 (38.1)	0.20 (5.2)	0.75 (19.1)
SS-FMA-MF6-NS8-H2	3/8	1/2	1.63 (41.3)	0.20 (5.2)	0.87 (22.2)
SS-FMA-MF9-NS6-H2	9/16	3/8	1.75 (44.5)	0.31 (7.9)	1.00 (25.4)
SS-FMA-MF9-NS8-H2	9/16	1/2	1.94 (49.2)	0.31 (7.9)	1.00 (25.4)

20D Series Tube Fittings to Male Medium Pressure

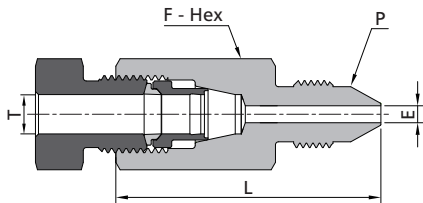

20D Series Tube Fittings			Male Medium Pressure		
Ordering Number	T-Tube O.D. in.	P-Size	Dimensions, in. (mm)		
			L	E	F
SS-FMA-DFF4-MM4-H2	1/4	1/4	1.67 (42.3)	0.11 (2.8)	0.63 (15.9)
SS-FMA-DFF4-MM6-H2	1/4	3/8	1.79 (45.5)	0.19 (4.8)	0.63 (15.9)
SS-FMA-DFF6-MM4-H2	3/8	1/4	1.82 (46.3)	0.11 (2.8)	0.75 (19.1)
SS-FMA-DFF6-MM6-H2	3/8	3/8	1.89 (47.9)	0.20 (5.2)	0.75 (19.1)
SS-FMA-DFF6-MM9-H2	3/8	9/16	1.94 (49.4)	0.25 (6.4)	0.94 (23.8)
SS-FMA-DFF8-MM6-H2	1/2	3/8	2.12 (53.8)	0.20 (5.2)	1.00 (25.4)
SS-FMA-DFF8-MM9-H2	1/2	9/16	2.24 (57.0)	0.31 (7.9)	1.00 (25.4)

BF Series Ball Valves

Features

- ⦿ FITOK's enhanced-316/316L stainless steel is available upon request for better hydrogen embrittlement resistance
- ⦿ Automatic compensation of seat sealing provides long service life
- ⦿ Special selected packing material provides better sealing for hydrogen applications
- ⦿ Low-temperature fluorocarbon O-ring complies with EC79 standards
- ⦿ Pneumatic actuator options available
- ⦿ Each valve leak tested with 6000 psig (414 bar) nitrogen or compressed air
- ⦿ 3-way valve configurations designed to receive inlet pressure on any port

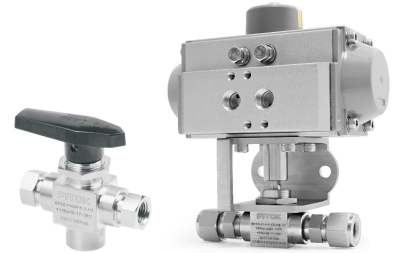

Technical Data

Max. Working Pressure	6000 psig (414 bar)
Working Temperature	-40~248 °F (-40~120 °C)
Body Material	316 SS
Seat Material	PEEK
O-ring	Low-temperature fluorocarbon

Ordering Information and Dimensions

Manual

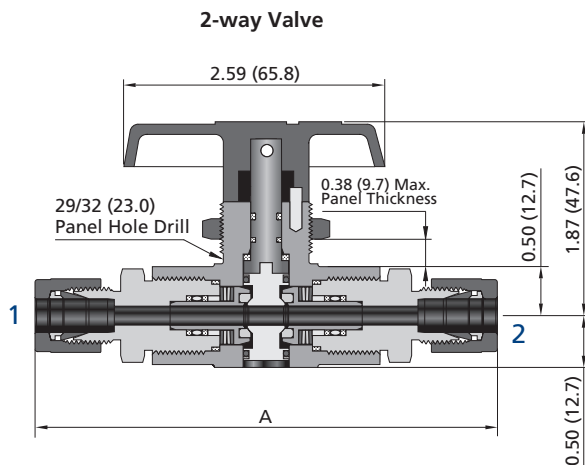

Ordering Number	Connection Type and Size		Orifice in. (mm)	Cv	Dimensions, in. (mm)
					A
BFSS-FL4-P-H2	6D Series Tube Fittings	1/4"	0.19 (4.8)	1.6	4.14 (105.2)
BFSS-FL6-P-H2		3/8"		1.4	4.39 (111.5)
BFSS-ML10-P-H2		10 mm	1.3	4.41 (112.0)	

3-way Valve

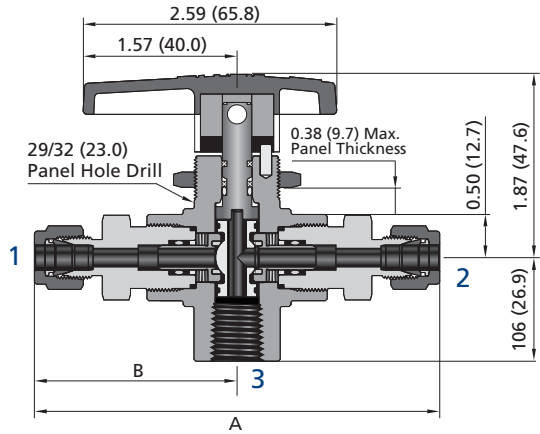

Ordering Number	Connection Type and Size				Orifice in. (mm)	Cv	Dimensions, in. (mm)	
	Connection 1 & 2		Connection 3				A	B
BFSS-FL4-P-3-H2	6D Series Tube Fittings	1/4"	Female NPT	1/4	0.19 (4.8)	0.75	4.14 (105.2)	2.07 (52.6)
BFSS-FL6-P-3-H2		3/8"					4.39 (111.5)	2.19 (55.6)
BFSS-ML10-P-3-H2		10 mm					4.41 (112.0)	2.20 (55.9)

Pneumatic Actuated

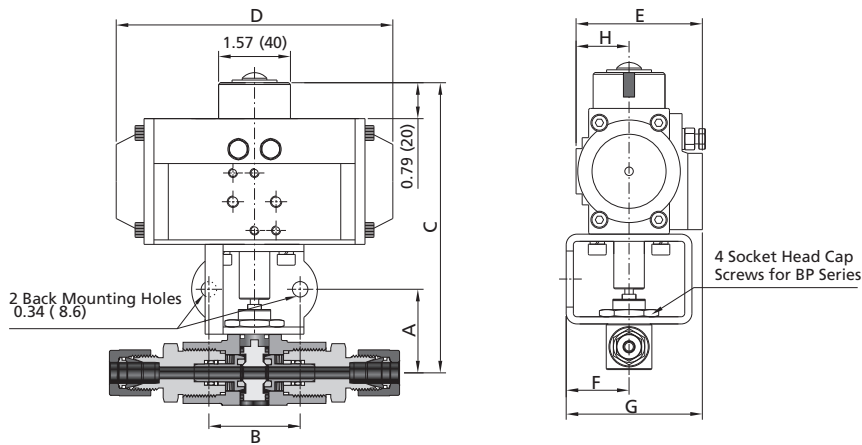

Ordering Number	Connection Type and Size		Orifice in. (mm)	Cv	Dimensions, in. (mm)							
					A	B	C	D	E	F	G	H
BFSS-FL4-P-O-H2	6D Series Tube Fittings	1/4"	0.19 (4.8)	1.6	1.48 (36.2)	2.00 (50.8)	6.01 (151.2)	6.06 (154.0)	2.78 (70.5)	1.38 (35.0)	3.01 (76.5)	1.14 (29.0)
BFSS-FL6-P-D-H2		3/8"		1.4								
BFSS-ML10-P-C-H2		10 mm		1.3								

Note: pneumatic actuator designators
 -C: 90° normally closed pneumatic actuator;
 -O: 90° normally open pneumatic actuator;
 -D: 90° double acting pneumatic actuator.

BU Series Ball Valves

Features

- ⦿ FITOK's enhanced-316/316L stainless steel is available upon request for better hydrogen embrittlement resistance
- ⦿ High flow-Cv from 4.0 to 13.8
- ⦿ Special selected packing material provides better sealing for hydrogen applications
- ⦿ Low-temperature fluorocarbon O-ring complies with EC79 standards
- ⦿ Spring-loaded seat provides leak-tight integrity in both low-and high-pressure systems and reduces seat wear from pressure surges
- ⦿ Each valve leak tested with 6000 psig (414 bar) nitrogen or compressed air
- ⦿ Panel mountable



Technical Data

Max. Working Pressure	6000 psig (414 bar)
Working Temperature	-40~250 °F (-40~121 °C)
Body Material	316 SS
Seat Material	PEEK
Stem/Seat O-ring	Low-temperature fluorocarbon
Packing Bolt Washer	Silver-plated 316 SS
Seat Backup Ring	PTFE

Ordering Information and Dimensions

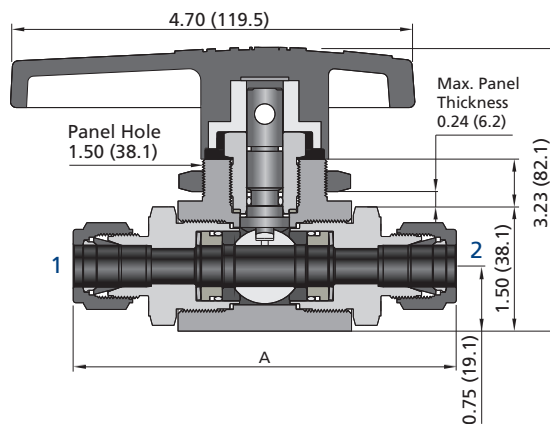

Ordering Number	Connection Type and Size	Orifice in. (mm)	Cv	Dimensions, in. (mm)	
				A	
BUSS-FL6-P12-H2	6D Series Tube Fittings	3/8"	0.28 (7.1)	4.0	4.20 (106.6)
BUSS-FL8-P12-H2		1/2"	0.41 (10.3)	7.2	4.40 (111.8)
BUSS-ML10-P12-H2		10 mm	0.31 (7.9)	5.2	4.21 (107.0)
BUSS-US12-P12-H2	Female SAE/MS	3/4-16	0.42 (10.7)	7.5	4.02 (102.0)

15B Series Ball Valves

Features

- FITOK's enhanced-316/316L stainless steel is available upon request for better hydrogen embrittlement resistance
- Trunnion mounted stem design
- Special selected packing material provides better sealing for hydrogen applications
- EPDM O-ring complies with EC79 standards
- Full-port flow path to minimize pressure drop
- Pneumatic actuator options available
- Each valve leak tested with 10150 psig (700 bar) nitrogen or compressed air

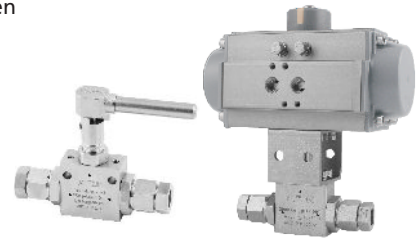

Technical Data

Max. Working Pressure	10152 psig at -40 °F (700 bar at -40 °C) 15000 psig at 185 °F (1034 bar at 85 °C)
Working Temperature	-40~185 °F (-40~85 °C)
Body Material	High tensile 316 SS
Seat Material	PEEK
O-ring	EPDM

For service in other temperature ranges, please contact FITOK Group or an authorized FITOK distributor.

Ordering Information and Dimensions

Manual

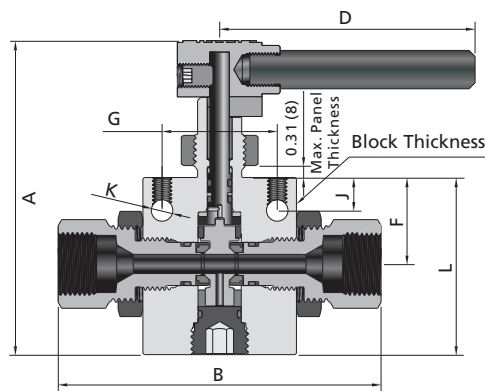

Ordering Number	Connection Type and Size		Orifice in. (mm)	Cv	Dimensions, in. (mm)								
					A	B	D	F	G	J	K	L	Block Thickness
15BSS-DFF4-4-1-H2	20D Series Tube Fittings	1/4"	0.19 (4.8)	1.27	4.09 (103.9)	4.19 (106.5)	3.33 (84.5)	1.13 (28.6)	1.50 (38.1)	0.43 (10.9)	0.28 (7.1)	2.31 (58.6)	1.00 (25.4)
15BSS-DFF6-4-1-H2		3/8"	0.25 (6.4)	1.51	4.84 (121.0)	5.53 (140.3)	4.96 (126.0)	1.38 (34.9)	2.00 (50.8)	0.41 (10.3)	0.28 (7.1)	2.95 (74.9)	1.38 (34.9)
15BSS-DFF8-6-1-H2		1/2"	0.37 (9.5)	3.51	4.09 (103.9)	4.19 (106.5)	3.33 (84.5)	1.13 (28.6)	1.50 (38.1)	0.43 (10.9)	0.28 (7.1)	2.31 (58.6)	1.00 (25.4)
15BSS-FNS4-4-1-H2	Female NPT	1/4"	0.25 (6.4)	1.51	4.09 (103.9)	4.19 (106.5)	3.33 (84.5)	1.13 (28.6)	1.50 (38.1)	0.43 (10.9)	0.28 (7.1)	2.31 (58.6)	1.00 (25.4)
15BSS-FNS6-4-1-H2		3/8"	0.25 (6.4)	1.51	4.09 (103.9)	4.19 (106.5)	3.33 (84.5)	1.13 (28.6)	1.50 (38.1)	0.43 (10.9)	0.28 (7.1)	2.31 (58.6)	1.00 (25.4)
15BSS-FNS8-4-1-H2		1/2"	0.25 (6.4)	1.51	4.09 (103.9)	4.19 (106.5)	3.33 (84.5)	1.13 (28.6)	1.50 (38.1)	0.43 (10.9)	0.28 (7.1)	2.31 (58.6)	1.00 (25.4)

Ordering Number	Connection Type and Size		Orifice in. (mm)	Cv	Dimensions, in. (mm)								
					A	B	D	F	G	J	K	L	Block Thickness
15BSS-FNS4-6-1-H2	Female NPT	1/4	0.37 (9.5)	3.51	4.84 (121.0)	5.53 (140.3)	4.96 (126.0)	1.38 (34.9)	2.00 (50.8)	0.41 (10.3)	0.28 (7.1)	2.95 (74.9)	1.38 (34.9)
15BSS-FNS6-6-1-H2		3/8	0.37 (9.5)	3.51									
15BSS-FNS8-6-1-H2		1/2	0.37 (9.5)	3.51									
15BSS-MF4-4-1-H2	20M Series Medium Pressure Fittings	1/4"	0.11 (2.8)	0.36	4.09 (103.9)	4.19 (106.5)	3.33 (84.5)	1.13 (28.6)	1.50 (38.1)	0.43 (10.9)	0.28 (7.1)	2.31 (58.6)	1.00 (25.4)
15BSS-MF6-4-1-H2		3/8"	0.20 (5.2)	1.23	4.84 (121.0)	5.53 (140.3)	4.96 (126.0)	1.38 (34.9)	2.00 (50.8)	0.41 (10.3)	0.28 (7.1)	2.95 (74.9)	1.38 (34.9)
15BSS-MF9-6-1-H2		9/16"	0.31 (7.9)	2.93									

Pneumatic Actuated

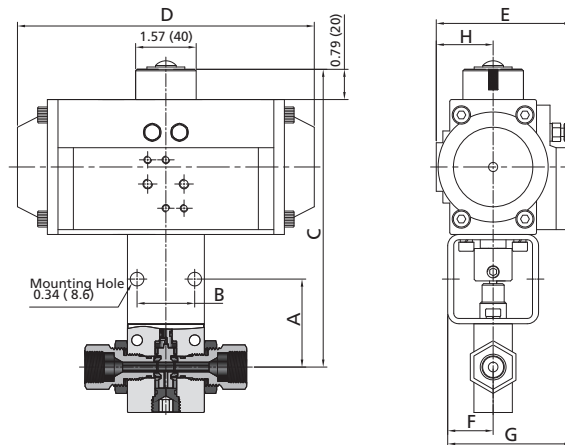

Ordering Number	Connection Type and Size		Orifice in. (mm)	Cv	Dimensions, in. (mm)								
					A	B	C	D	E	F	G	H	Block Thickness
15BSS-DFF4-4-1-C-H2	20D Series Tube Fittings	1/4"	0.19 (4.8)	1.27	2.29 (58.1)	1.50 (38.1)	7.74 (196.6)	7.44 (189.0)	3.52 (89.6)	1.57 (40.0)	3.60 (91.5)	1.50 (38.0)	1.00 (25.4)
15BSS-DFF6-4-1-O-H2		3/8"	0.25 (6.4)	1.51	2.56 (64.9)	2.00 (50.8)	8.03 (203.9)	7.44 (189.0)	3.52 (89.6)	1.97 (50.0)	4.00 (101.6)	1.50 (38.0)	1.38 (34.9)
15BSS-DFF8-6-1-D-H2		1/2"	0.37 (9.5)	3.51									
15BSS-FNS4-4-1-C-H2	Female NPT	1/4	0.25 (6.4)	1.51	2.29 (58.1)	1.50 (38.1)	7.74 (196.6)	7.44 (189.0)	3.52 (89.6)	1.57 (40.0)	3.60 (91.5)	1.50 (38.0)	1.00 (25.4)
15BSS-FNS6-6-1-C-H2		3/8	0.37 (9.5)	3.51	2.56 (64.9)	2.00 (50.8)	8.97 (227.9)	9.02 (229.0)	4.43 (112.5)	1.97 (50.0)	4.47 (113.5)	1.93 (49.0)	1.38 (34.9)
15BSS-FNS8-6-1-O-H2		1/2	0.37 (9.5)	3.51	2.29 (58.1)	1.50 (38.1)	7.74 (196.6)	7.44 (189.0)	3.52 (89.6)	1.57 (40.0)	3.60 (91.5)	1.50 (38.0)	1.00 (25.4)
15BSS-MF4-4-1-C-H2	20M Series Medium Pressure Fittings	1/4"	0.11 (2.8)	0.36									
15BSS-MF6-4-1-C-H2		3/8"	0.20 (5.2)	1.23									
15BSS-MF9-6-1-D-H2		9/16"	0.31 (7.9)	2.93									

Note: pneumatic actuator designators

- C: 90° normally closed pneumatic actuator;
- O: 90° normally open pneumatic actuator;
- D: 90° double acting pneumatic actuator.

NF Series Needle Valves

Features

- ⦿ FITOK's enhanced-316/316L stainless steel is available upon request for better hydrogen embrittlement resistance
- ⦿ One-piece forged body
- ⦿ Upper stem thread lubricant isolated from system media
- ⦿ Special selected packing material provides better sealing for hydrogen applications
- ⦿ Special treated surface of the stem tip provides better shut-off and sealing for hydrogen gas
- ⦿ Each valve leak tested with 6000 psig (414 bar) nitrogen or compressed air
- ⦿ Panel mounting available upon request



Technical Data

Max. Working Pressure	6000 psig (414 bar)
Working Temperature	-40~450 °F (-40~232 °C)
Body Material	316 SS
Packing Material	PTFE
Stem Tip Material	Hardened 316 SS
Stem Tip Type	Taper

Ordering Information and Dimensions

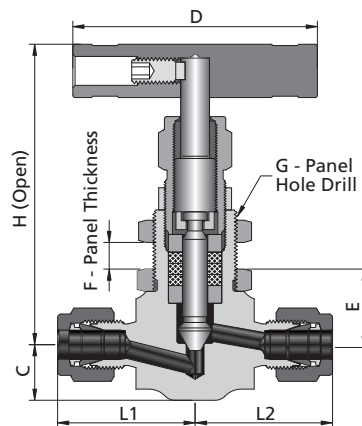

Ordering Number	Connection Type and Size	Orifice in. (mm)	Cv	Dimensions, in. (mm)								
				L1	L2	H	D	C	E	F	G	
NFSS-FL4-7-Y-H2	6D Series Tube Fittings	1/4"	0.16 (4.0)	0.35	1.22 (30.9)	1.22 (30.9)	2.85 (72.5)	2.17 (55.0)	0.49 (12.5)	0.71 (18.0)	0.25 (6.4)	0.77 (19.6)
NFSS-FL6-8-Y-H2		3/8"	0.25 (6.4)	0.85	1.44 (36.5)	1.44 (36.5)	3.38 (85.8)	2.50 (63.5)	0.62 (15.8)	0.87 (22.0)	0.38 (9.7)	0.96 (24.4)

15N Series Needle Valves

Features

- ◎ FITOK's enhanced-316/316L stainless steel is available upon request for better hydrogen embrittlement resistance
- ◎ Special selected packing material provides better sealing for hydrogen applications
- ◎ Special treated surface of the stem tip provides better shut-off and sealing for hydrogen gas
- ◎ Each valve leak tested with 10150 psig (700 bar) nitrogen or compressed air



Technical Data

Needle Valve	
Max. Working Pressure	15000 psig (1034 bar)
Working Temperature	-40~450 °F (-40~232 °C)
Body Material	High tensile 316 SS
Packing Material	PTFE

Actuator	
Max. Working Pressure	100 psig (6.9 bar)
Working Temperature	-10~200 °F (-23~93 °C)
Cylinder Material	Anodized Aluminum
O-ring Material	Buna N

Ordering Information and Dimensions

Manual

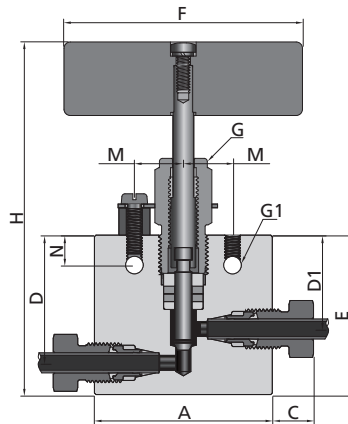

Ordering Number	Connection Type and Size		Orifice in. (mm)	Cv	Dimensions, in. (mm)											
					A	C	D	D1	E	F	G	G1	H	M	N	Block Thickness
15NSS-DFF4-1-H2	20D Series Tube Fittings	1/4"	0.19 (4.8)	0.65	2.33 (59.2)	0.52 (13.3)	1.62 (41.2)	1.19 (30.2)	2.00 (50.8)	3.00 (76.2)	0.75 (19.1)	0.22 (5.6)	4.90 (124.5)	0.62 (15.8)	0.38 (9.7)	0.75 (19.1)
15NSS-DFF6-1-H2		3/8"	0.25 (6.4)	0.95	2.27 (57.6)	0.54 (13.6)	1.62 (41.2)	1.19 (30.2)	2.00 (50.8)	3.00 (76.2)	0.75 (19.1)	0.22 (5.6)	4.97 (126.3)	0.62 (15.8)	0.38 (9.7)	0.75 (19.1)
15NSS-DFF8-1-H2		1/2"	0.37 (9.5)	1.90	2.86 (72.7)	0.60 (15.3)	2.37 (60.3)	1.75 (44.5)	2.88 (73.2)	4.00 (101.6)	1.00 (25.4)	0.34 (8.6)	6.21 (157.7)	0.69 (17.5)	0.50 (12.7)	1.00 (25.4)

Pneumatic Actuated

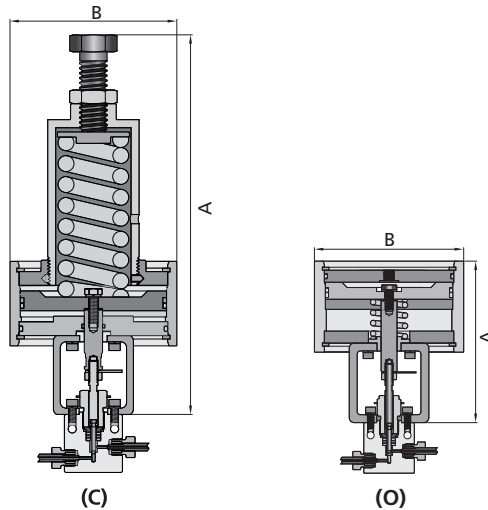

Ordering Number	Connection Type and Size		Orifice in. (mm)	Cv	Area of Piston sq.in. (sq. cm)	Dimensions, in. (mm)	
						A	B
15NSS-DF4-1-C-H2	20D Series Tube Fittings	1/4"	0.19 (4.8)	0.65	19.95 (128.7)	13.08 (332.3)	5.75 (146.0)
15NSS-DF6-1-O-H2		3/8"	0.25 (6.4)	0.95	19.95 (128.7)	5.94 (151.0)	5.75 (146.0)
15NSS-DF8-1-C-H2		1/2"	0.37 (9.5)	1.90	51.20 (330.3)	16.24 (412.5)	6.54 (166.0)

Note: pneumatic actuator designators

- C: normally closed pneumatic actuator;
- O: normally open pneumatic actuator.

20N Series Needle Valves

Features

- ⦿ FITOK's enhanced-316/316L stainless steel is available upon request for better hydrogen embrittlement resistance
- ⦿ Special selected packing material provides better sealing for hydrogen applications
- ⦿ Special treated surface of the stem tip provides better shut-off and sealing for hydrogen gas
- ⦿ Each valve leak tested with 10150 psig (700 bar) nitrogen or compressed air



Technical Data

Needle Valve	
Max. Working Pressure	20000 psig (1379 bar)
Working Temperature	-40~450 °F (-40~232 °C)
Body Material	High tensile 316 SS
Packing Material	PTFE

Actuator	
Max. Working Pressure	100 psig (6.9 bar)
Working Temperature	-10~200 °F (-23~93 °C)
Cylinder Material	Anodized Aluminum
O-ring Material	Buna N

Ordering Information and Dimensions

Manual

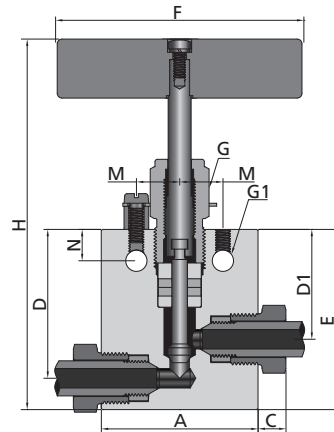

Ordering Number	Connection Type and Size		Orifice in. (mm)	Cv	Dimensions, in. (mm)											
					A	C	D	D1	E	F	G	G1	H	M	N	Block Thickness
20NSS-MF4-1-H2	20M Series Medium Pressure Fittings	1/4"	0.13 (3.2)	0.31	2.00 (50.8)	0.38 (9.7)	1.62 (41.2)	1.19 (30.2)	2.00 (50.8)	3.00 (76.2)	0.75 (19.1)	0.22 (5.6)	4.85 (123.1)	0.62 (15.8)	0.38 (9.7)	0.75 (19.1)
20NSS-MF6-1-H2		3/8"	0.20 (5.2)	0.68	2.00 (50.8)	0.44 (11.2)	1.62 (41.2)	1.19 (30.2)	2.00 (50.8)	3.00 (76.2)	0.75 (19.1)	0.22 (5.6)	4.89 (124.2)	0.62 (15.8)	0.38 (9.7)	0.75 (19.1)
20NSS-MF9-1-H2		9/16"	0.31 (7.9)	1.30	2.50 (63.5)	0.55 (14.0)	2.37 (60.3)	1.75 (44.5)	2.88 (73.2)	4.00 (101.6)	1.00 (25.4)	0.34 (8.6)	6.18 (157.2)	0.69 (17.5)	0.50 (12.7)	1.00 (25.4)

Pneumatic Actuated

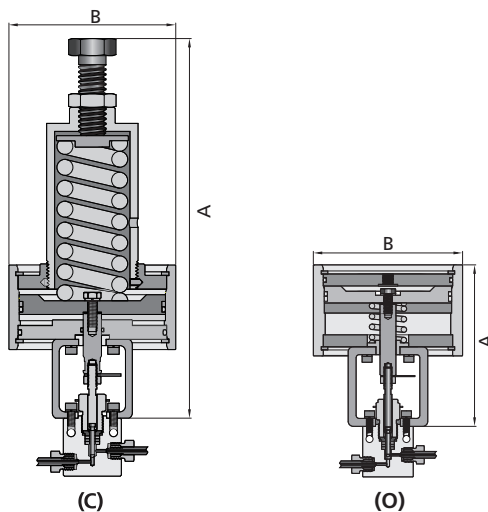

Ordering Number	Connection Type and Size		Orifice in. (mm)	Cv	Area of Piston sq.in. (sq. cm)	Dimensions, in. (mm)	
						A	B
20NSS-MF4-1-C-H2	20M Series Medium Pressure Fittings	1/4"	0.13 (3.2)	0.31	19.95 (128.7)	13.08 (332.3)	5.75 (146.0)
20NSS-MF6-1-O-H2		3/8"	0.20 (5.2)	0.68	19.95 (128.7)	5.94 (151.0)	5.75 (146.0)
20NSS-MF9-1-C-H2		9/16"	0.31 (7.9)	1.30	51.20 (330.3)	16.24 (412.5)	6.54 (166.0)

Note: pneumatic actuator designators
 -C: normally closed pneumatic actuator;
 -O: normally open pneumatic actuator.

CH Series Check Valves

Features

- ◎ FITOK's enhanced-316/316L stainless steel is available upon request for better hydrogen embrittlement resistance
- ◎ Higher manufacturing and inspection standards
- ◎ Mounting in any direction is acceptable
- ◎ Each valve leak tested with 6000 psig (414 bar) nitrogen or compressed air



Technical Data

Max. Working Pressure	6000 psig (414 bar)
Cracking Pressure	0~30 psig (0~2.1 bar)
Working Temperature	-40~248 °F (-40~120 °C)
Body Material	316 SS
O-ring	EPDM

Ordering Information and Dimensions

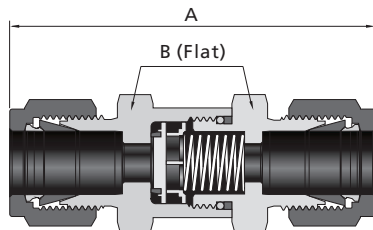

Ordering Number	Connection Type and Size	Cv	Cracking Pressure Range, psig (bar)	Dimensions, in. (mm)		
				A	B	
CHSS-FL4-H2	6D Series Tube Fittings	1/4"	0.67	1~5 (0.06~0.34)	2.43 (61.7)	11/16 (17.5)
CHSS-FL4-1-H2		1/4"	0.67	0~3 (0~0.21)	2.43 (61.7)	11/16 (17.5)
CHSS-FL6-2-H2		3/8"	1.80	0~4 (0~0.28)	2.75 (69.9)	1.0 (25.4)
CHSS-FL6-3-H2		3/8"	1.80	7~15 (0.49~1.1)	2.75 (69.9)	1.0 (25.4)
CHSS-FL8-4-H2		1/2"	1.80	20~30 (1.4~2.1)	2.96 (75.2)	1.0 (25.4)

15C Series Check Valves

Features

- ◎ FITOK's enhanced-316/316L stainless steel is available upon request for better hydrogen embrittlement resistance
- ◎ Higher manufacturing and inspection standards
- ◎ Mounting in any direction is acceptable
- ◎ Each valve leak tested with 10150 psig (700 bar) nitrogen or compressed air



Technical Data

Max. Working Pressure	15000 psig (1034 bar)
Cracking Pressure	14~26 psig (0.966~1.794 bar)
Working Temperature	-40~185 °F (-40~85 °C)
Body Material	316 SS
O-ring	EPDM

Ordering Information and Dimensions

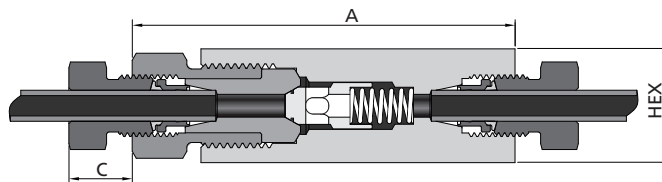

Ordering Number	Connection Type and Size		Orifice in. (mm)	Cv	Dimensions, in. (mm)		
					A	C	HEX
15CSS-DFF4-H2	20D Series Tube Fittings	1/4"	0.19 (4.9)	0.63	3.35 (85.0)	0.52 (13.3)	0.81 (20.6)
15CSS-DFF6-H2		3/8"	0.25 (6.4)	1.70	3.72 (94.6)	0.53 (13.5)	1.00 (25.4)
15CSS-DFF8-H2		1/2"	0.36 (9.12)	2.30	4.41 (112.0)	0.60 (15.3)	1.38 (35.1)
15CSS-FNS4-H2	Female NPT	1/4"	0.12 (3.1)	0.28	4.41 (112.0)	—	1.38 (35.1)
15CSS-FNS6-H2		3/8"	0.22 (5.6)	0.84	4.41 (112.0)	—	1.38 (35.1)
15CSS-FNS8-H2		1/2"	0.36 (9.1)	2.30	4.41 (112.0)	—	1.38 (35.1)

20C Series Check Valves

Features

- ⦿ FITOK's enhanced-316/316L stainless steel is available upon request for better hydrogen embrittlement resistance
- ⦿ Higher manufacturing and inspection standards
- ⦿ Mounting in any direction is acceptable
- ⦿ Each valve leak tested with 10150 psig (700 bar) nitrogen or compressed air



Technical Data

Max. Working Pressure	20000 psig (1379 bar)
Cracking pressure	14~26 psig (0.966~1.794 bar)
Working Temperature	-40~185 °F (-40~85 °C)
Body Material	316 SS
O-ring	EPDM

Ordering Information and Dimensions

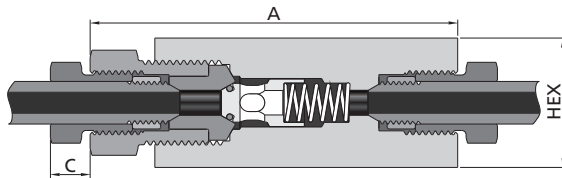

Ordering Number	Connection Type and Size		Orifice in. (mm)	Cv	Dimensions, in. (mm)		
					A	C	HEX
20CSS-MF4-H2	20M Series Medium Pressure Fittings	1/4"	0.13 (3.2)	0.28	2.94 (74.7)	0.38 (9.7)	0.81 (20.6)
20CSS-MF6-H2		3/8"	0.22 (5.5)	0.84	3.12 (79.3)	0.44 (11.2)	1.00 (25.4)
20CSS-MF9-H2		9/16"	0.36 (9.1)	2.30	4.18 (106.2)	0.55 (14.0)	1.38 (35.1)

RO Series Proportional Relief Valves

Features

- ◎ FITOK's enhanced-316/316L stainless steel is available upon request for better hydrogen embrittlement resistance
- ◎ Higher manufacturing and inspection standards
- ◎ Set pressure can be customized and marked on a tag with a lead seal lock wire
- ◎ Large orifice for high flow and rapid pressure release
- ◎ Designed to eliminate back-pressure effect
- ◎ Each valve is factory tested at the set pressure



Technical Data

Working Pressure	145 psig (10 bar)
Set Pressure	14.5~29 psig (1.0~2.0 bar)
Blowdown	≤4.4 psig (0.3 bar)
Working Temperature	-40~275 °F (-40~135 °C)
Body Material	316 SS
O-ring	EPDM

Ordering Information and Dimensions

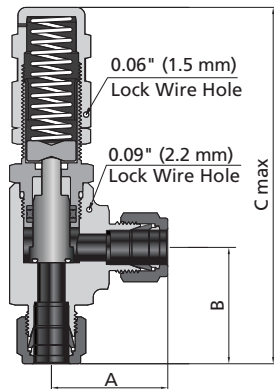

Ordering Number	Connection Type and Size		Orifice in. (mm)	Cv	Dimensions, in. (mm)		
					A	B	C
ROSS-FL8-10-H2	6D Series Tube Fittings	1/2"	0.39 (10.0)	2.62	1.71 (43.4)	1.71 (43.4)	5.23 (132.9)

RV Series Proportional Relief Valves

Features

- ◎ FITOK's enhanced-316/316L stainless steel is available upon request for better hydrogen embrittlement resistance
- ◎ Higher manufacturing and inspection standards are applied for hydrogen applications
- ◎ Set pressure can be customized and marked on a tag with a lead seal lock wire
- ◎ Designed to eliminate back-pressure effect
- ◎ Each valve is factory tested at the set pressure



Technical Data

Max. Outlet Pressure	1500 psig (103 bar)
Set Pressure	50~6000 psig (3.4~414 bar)
Working Temperature	-40~250 °F (-40~121 °C)
Body Material	316 SS
O-ring	EPDM

Ordering Information and Dimensions

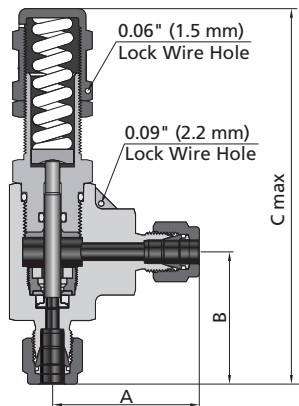

Ordering Number	Connection Type and Size		Orifice in. (mm)	Cv	Set Pressure Range, psig (bar)	Dimensions, in. (mm)		
						A	B	C
RVSS-FL4-6-C-H2	6D Series Tube Fittings	1/4"	0.14 (3.6)	0.41	4500~6000 (310~414)	1.60 (40.6)	1.44 (36.6)	4.14 (105.2)
RVSS-FL6-6-J-H2		3/8"			3500~4500 (241~310)	1.60 (40.6)	1.44 (36.6)	4.14 (105.2)
RVSS-FL8-6-W-H2		1/2"			2500~3500 (172~241)	1.72 (43.7)	1.72 (43.7)	5.81 (147.6)
RVSS-ML6-6-P-H2		6 mm			1500~2500 (103~172)	1.60 (40.6)	1.44 (36.6)	4.14 (105.2)
RVSS-ML8-6-Y-H2		8 mm			700~1500 (48.3~103)	1.60 (40.6)	1.44 (36.6)	4.14 (105.2)
RVSS-ML12-6-O-H2		12 mm			300~700 (20.7~48.3)	1.83 (46.5)	1.83 (46.5)	5.92 (150.4)
RVSS--ML12-6-F-H2		12 mm			50~300 (3.4~20.7)	1.83 (46.5)	1.83 (46.5)	5.92 (150.4)

RL Series Proportional Relief Valves

Features

- © FITOK's enhanced-316/316L stainless steel is available upon request for better hydrogen embrittlement resistance
- © Higher manufacturing and inspection standards are applied for hydrogen applications
- © Set pressure can be customized and marked on a tag with a lead seal lock wire
- © Each valve is factory tested at the set pressure



Technical Data

Max. Outlet Pressure	225 psig (15.5 bar)
Set Pressure	10~225 psig (0.68~15.5 bar)
Pre-set Pressure	Desired pressure - 0.8 x Back pressure
Working Temperature	-40~250 °F (-40~121 °C)
Body Material	316 SS
O-ring	EPDM

Ordering Information and Dimensions

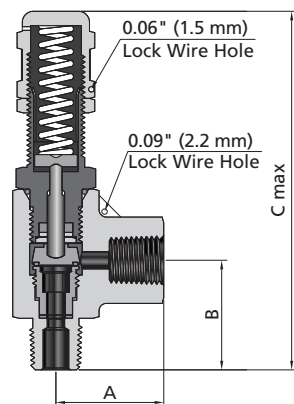

Ordering Number	Connection Type and Size				Orifice in. (mm)	Cv	Dimensions, in. (mm)		
	Inlet		Outlet				A	B	C
RLSS-NS4-FNS4-7-H2	Male NPT	1/4	Female NPT	1/4	0.19 (4.8)	0.6	1.17 (29.7)	1.37 (34.9)	4.07 (103.5)
RLSS-NS8-FNS8-8-H2		1/2	Female NPT	1/2	0.25 (6.4)	0.8	1.44 (36.6)	1.44 (36.6)	5.52 (140.0)

HSR Series Relief Valves

Features

- ◎ FITOK's enhanced-316/316L stainless steel is available upon request for better hydrogen embrittlement resistance
- ◎ Soft seat design to provide bubble tight shut-off for gas applications
- ◎ Set pressure can be customized and marked on a tag with a lead seal lock wire
- ◎ Mounting in any direction is acceptable
- ◎ Each valve is factory tested at the set pressure



Technical Data

Max.Working Pressure	20000 psig (1379 bar)	
Set Pressure	HSRSS-MF9-FNS12-1-H2	1500~5000 psig (103~345 bar)
	HSRSS-MF9-FNS12-2-H2	5000~10000 psig (345~690 bar)
	HSRSS-MF9-FNS12-3-H2	10000~20000 psig (690~1379 bar)
Maximum Back Pressure	500 psig (34.5 bar)	
Working Temperature	-40~400 °F (-40~204 °C)	
Body Material	316 SS	

Notes: 1. Please specify the required set pressure when ordering.
2. Maximum system operating pressure should not exceed 90% of the set pressure.

Ordering Information and Dimensions

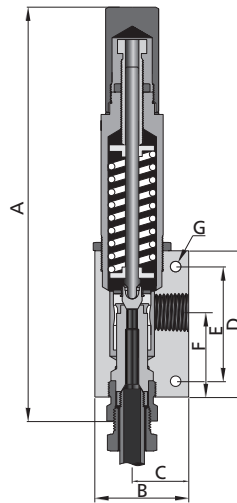

Ordering Number	Connection Type and Size			Orifice in. (mm)	Cv	Dimensions, in.(mm)							
	Inlet	Outlet				A	B	C	D	E	F	G	
HSRSS-MF9-FNS12-1-H2	20M Series Medium Pressure Fittings	9/16"	Female NPT 3/4		0.31 (7.9)	1.2	9.46 (240.4)	2.00 (50.8)	1.19 (30.2)	3.25 (82.6)	2.25 (57.1)	1.94 (49.3)	0.28 (7.1)
HSRSS-MF9-FNS12-2-H2					0.25 (6.4)	0.8							
HSRSS-MF9-FNS12-3-H2					0.16 (4.0)	0.3							

Note: G is the diameter of mounting holes.

EV Series Excess Flow Valves

Features

- FITOK's enhanced-316/316L stainless steel is available upon request for better hydrogen embrittlement resistance
- The flow going through the bleed vent is lower than 1% of the flow rate in the trip range



Technical Data

Max. Working Pressure	6000 psig (414 bar)
Working Temperature	-40~250 °F (-40~121 °C)
Body Material	316 SS
O-ring	EPDM

Ordering Information and Dimensions

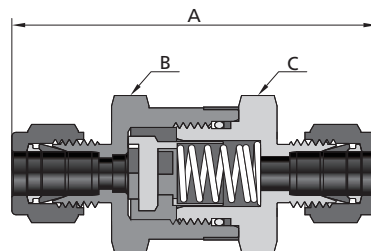

Ordering Number	Connection Type and Size	Orifice in. (mm)	Cv	Dimensions, in. (mm)			
				A	B	C	
EVSS-FL4-4-H2	6D Series Tube Fittings	1/4"	0.19 (4.8)	0.5	2.43 (61.7)	0.69 (17.5)	0.69 (17.5)
EVSS-FL6-6-H2		3/8"	0.25 (6.4)	1.1	2.75 (69.9)	1.0 (25.4)	1.0 (25.4)
EVSS-ML12-8-H2		12 mm	0.37 (9.5)	1.1	2.96 (75.2)	1.0 (25.4)	1.0 (25.4)

Flow Data at 70°F (20°C)

Air Flow

EVSS-FL4-4-H2

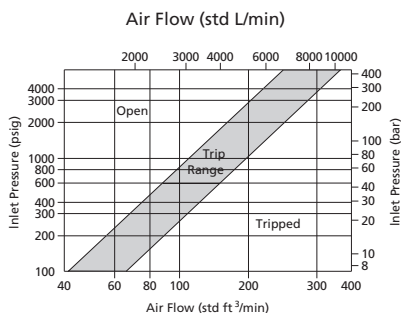

EVSS-FL6-6-H2

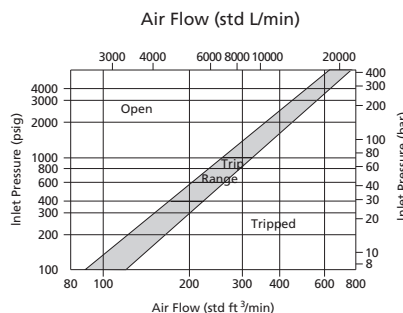

EVSS-ML12-8-H2

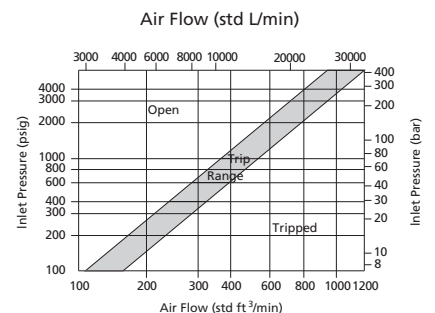

Filters



FT Series Filters

Features

- FITOK's enhanced-316/316L stainless steel is available upon request for better hydrogen embrittlement resistance
- Higher manufacturing and inspection standards
- Filter element replaceable without removing body from system
- Nominal pore sizes for sintered element: 7 and 15 μm



Technical Data

Max. Working Pressure	6000 psig (414 bar)
Max. Differential Pressure	1000 psig (69 bar)
Working Temperature	-40~900 °F (-40~482 °C)
Body Material	316 SS
Filter Element	Sintered 316 SS
Gasket	316 SS, Silver-plated

Ordering Information and Dimensions

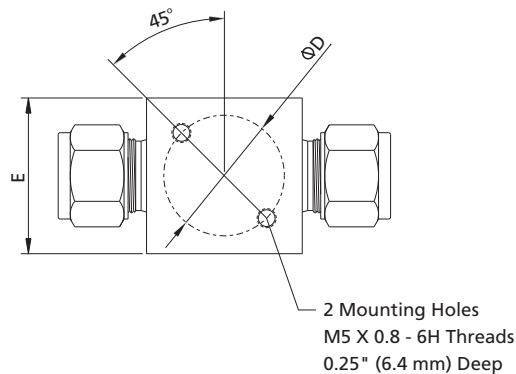
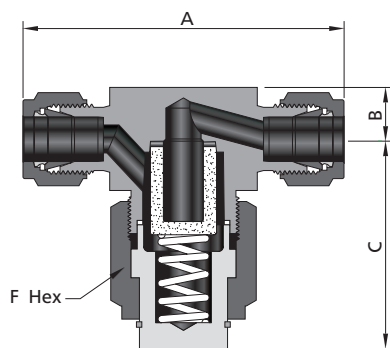

Ordering Number	Connection Type and Size	Orifice in. (mm)	Nominal Pore Size	Effective Filter Element Area in. ² (mm ²)	Dimensions, in. (mm)						
					A	B	C	ØD	E	F	
FTSS-FL4-7-H2	6D Series Tube Fittings	1/4"	0.17 (4.4)	7	1.30 (830)	2.47 (62.7)	0.38 (9.7)	1.49 (37.8)	1.00 (25.4)	1.00 (25.4)	1 (25.4)
FTSS-FL4-15-H2			15								
FTSS-FL6-7-H2		3/8"	0.25 (6.4)	7	2.00 (1280)	2.84 (72.1)	0.46 (11.7)	1.74 (44.2)	1.13 (28.6)	1.13 (28.6)	1.13 (28.6)
FTSS-FL6-15-H2				15							
FTSS-FL8-7-H2		1/2"	0.25 (6.4)	7	2.00 (1280)	3.04 (77.2)	0.46 (11.7)	1.74 (44.2)	1.13 (28.6)	1.13 (28.6)	1.13 (28.6)
FTSS-FL8-15-H2				15							

15FC Series Filters

Features

- ⦿ FITOK's enhanced-316/316L stainless steel is available upon request for better hydrogen embrittlement resistance
- ⦿ Higher manufacturing and inspection standards
- ⦿ Cup design offers approximately six times the effective filter area as compared to disc-type units for high flow service
- ⦿ Easy to replace filter element
- ⦿ Pressure differential not to exceed 1000 psig (69 bar) in a flowing condition
- ⦿ 5 μ m element nominal pore size as standard, additional sizes available upon request



Technical Data

Max. Working Pressure	15000 psig (1034 bar)
Working Temperature	-60~400 °F (-50~204 °C)
Body Material	316 SS

Ordering Information and Dimensions

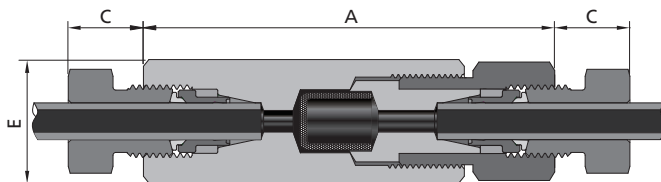

Ordering Number	Connection Type and Size		Orifice in. (mm)	Nominal Pore Size	Effective Filter Element Area in. ² (mm ²)	Dimensions, in. (mm)		
						A	C	E (Hex)
15FCSS-DF4-5-H2	20D Series Tube Fittings	1/4"	0.19 (4.8)	5	0.81 (522.6)	3.34 (84.8)	0.52 (13.3)	0.81 (20.6)
15FCSS-DF6-5-H2		3/8"	0.31 (7.9)	5	0.81 (522.6)	3.51 (89.2)	0.54 (13.6)	1.00 (25.4)
15FCSS-DF8-5-H2		1/2"	0.44 (11.1)	5	1.53 (987.1)	4.30 (109.2)	0.60 (15.3)	1.38 (35.0)
15FCSS-FNS4-5-H2	Female NPT	1/4"	0.31 (7.9)	5	0.81 (522.6)	3.66 (93.0)	—	1.00 (25.4)
15FCSS-FNS6-5-H2		3/8"	0.31 (7.9)	5	0.81 (522.6)	3.66 (93.0)	—	1.13 (28.6)
15FCSS-FNS8-5-H2		1/2"	0.44 (11.1)	5	1.53 (987.1)	4.55 (115.6)	—	1.38 (35.0)

20FC Series Filters

Features

- ◎ FITOK's enhanced-316/316L stainless steel is available upon request for better hydrogen embrittlement resistance
- ◎ Higher manufacturing and inspection standards
- ◎ Cup design offers approximately six times the effective filter area as compared to disc-type units for high flow service
- ◎ Easy to replace filter element
- ◎ Pressure differential not to exceed 1000 psig (69 bar) in a flowing condition
- ◎ 5 μm element nominal pore size as standard, additional sizes available upon request



Technical Data

Max. Working Pressure	20000 psig (1379 bar)
Working Temperature	-60~400 °F (-50~204 °C)
Body Material	316 SS

Ordering Information and Dimensions

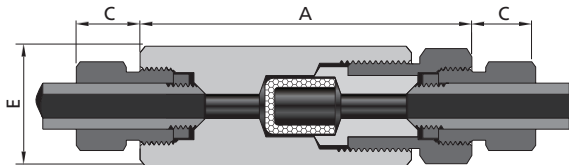

Ordering Number	Connection Type and Size		Orifice in. (mm)	Nominal Pore Size	Effective Filter Element Area in. ² (mm ²)	Dimensions, in. (mm)		
						A	C	E (Hex)
20FCSS-MF4-5-H2	20M Series Medium Pressure Fitting	1/4"	0.13 (3.2)	5	0.81 (522.6)	2.94 (74.1)	0.38 (9.7)	0.81 (20.6)
20FCSS-MF6-5-H2		3/8"	0.22 (5.5)	5	0.81 (522.6)	3.12 (79.3)	0.44 (11.2)	1.00 (25.4)
20FCSS-MF9-5-H2		9/16"	0.36 (9.1)	5	1.53 (987.1)	4.18 (106.2)	0.55 (14.0)	1.38 (35.0)

Quick-Connects



QC Series Quick-Connects

Features

- ◎ FITOK's enhanced-316/316L stainless steel is available upon request for better hydrogen embrittlement resistance
- ◎ Reliable, leak-tight O-ring seal for vacuum or pressure applications
- ◎ Interchangeable with other key manufacturers' products
- ◎ Push-to-connect coupling to enable quick and easy operation
- ◎ Locking mechanism with large contact area to ensure reliable stem retainment
- ◎ Stem protector, body protector and keyed options available
- ◎ Each quick-connect leak tested with compressed air at the maximum allowable working pressure in coupled and uncoupled status

Technical Data

	Coupled	Uncoupled and When Coupling and Uncoupling
Max. Working Pressure	QC4: 3000 psig (207 bar) QC6: 1500 psig (103 bar)	QC4: 250 psig (17.2 bar) QC6: 250 psig (17.2 bar)
Working Temperature	-40~250 °F (-40~121 °C)	
Body Material	316 SS	

Ordering Information and Dimensions

Bodies

Female NPT

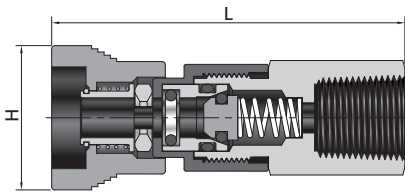

NPT Size in.	Ordering Number	Dimensions	
		H	L
		in. (mm)	in. (mm)
1/4	SS-QC4-FNS4-B-H2	0.91 (23.1)	2.42 (61.5)
1/4	SS-QC6-FNS4-B-H2	1.03 (26.2)	2.54 (64.5)

DESO Stems

Female NPT

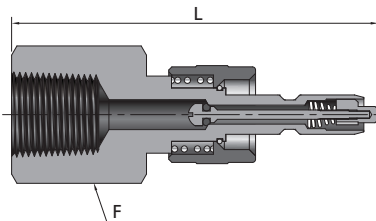

BSPT Size in.	Ordering Number	Flow Coefficient (Cv)	Dimensions	
			F	L
			in. (mm)	in. (mm)
1/4	SS-QC4-FNS4-D-H2	0.2	0.75 (19.05)	2.32 (58.9)
1/4	SS-QC6-FNS4-D-H2	0.5	0.75 (19.05)	2.47 (62.7)

Metal Hoses



MH & MM Series Metal Hoses

Features

- ⦿ Core tube and fitting material: 316 SS
- ⦿ Overbraid material: 304 SS
- ⦿ Welded fitting-to-hose construction to ensure reliable seal
- ⦿ Suitable for hydrogen gas service where permeation is not accepted
- ⦿ Stock components for on-demand customized hose assemblies
- ⦿ Every hose is factory tested with helium to a maximum leak rate of 1×10^{-10} Pa m³/s

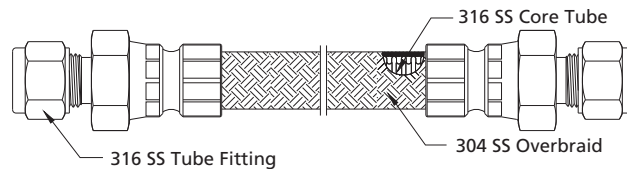

Technical Data

MH Series							
Nominal Hose Size	Inside Diameter	Min. Bend Radius		Temperature Range	Working Pressure at 70 °F (20 °C)	Burst Pressure at 70 °F (20 °C)	Series and Size Designator
		Static	Dynamic				
		in. (mm)	in. (mm)				
1/4 (6.4)	0.28 (7.1)	2.25 (57.2)	10.00 (254.0)	-325~800 (-200~426)	3100 (213)	12400 (854)	MH4
3/8 (9.7)	0.42 (10.6)	3.00 (76.2)	12.00 (305.0)		2000 (137)	8000 (551)	MH6
1/2 (12.7)	0.53 (13.5)	4.50 (114)	16.00 (406.0)		1800 (124)	7200 (496)	MH8

MM Series							
Nominal Hose Size	Inside Diameter	Min. Bend Radius		Temperature Range	Working Pressure at 70 °F (20 °C)	Burst Pressure at 70 °F (20 °C)	Series and Size Designator
		Annular Convolute Core					
		Static	Dynamic				
in. (mm)	in. (mm)	in. (mm)	in. (mm)	°F (°C)	psig (bar)	psig (bar)	
1/4 (6.4)	0.25 (6.4)	0.79 (20.0)	4.33 (110.0)	-325~800 (-200~426)	1600 (110)	6400 (440)	MM4
3/8 (9.7)	0.37 (9.5)	0.98 (25.0)	5.91 (150.0)		1470 (101)	6000 (413)	MM6
1/2 (12.7)	0.50 (12.7)	1.18 (30.0)	4.88 (124.0)		1110 (76.4)	4500 (310)	MM8

Ordering Information and Dimensions

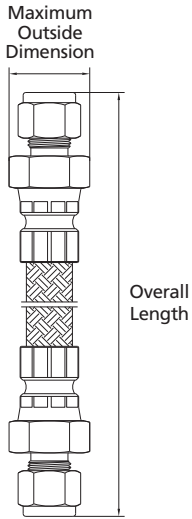

Tube Fitting End

Ordering Number	Nominal Hose Size	Tube Fitting Size	Overall Length	Minimum Inside Diameter	Maximum Outside Dimension
		in.	in. (mm)	in. (mm)	in. (mm)
SS-MH4-FL4-F24-H2	1/4	1/4	24.00 (610.0)	0.19 (4.8)	0.94 (23.8)
SS-MM4-FL4-F36-R-H2			36.00 (914.0)	0.19 (4.8)	0.87 (22.0)
SS-MH4-FL4-M1000-H2			39.40 (1000.0)	0.19 (4.8)	0.94 (23.8)
SS-MH6-FL6-F24-H2	3/8	3/8	24.00 (610.0)	0.28 (7.1)	1.09 (27.7)
SS-MM6-FL6-F36-R-H2			36.00 (914.0)	0.28 (7.1)	1.01 (25.7)
SS-MM6-FL6-M1000-R-H2			39.40 (1000.0)	0.28 (7.1)	1.01 (25.7)
SS-MH8-FL8-F24-H2	1/2	1/2	24.00 (610.0)	0.41 (10.4)	1.30 (33.1)
SS-MM8-FL8-F36-R-H2			36.00 (914.0)	0.41 (10.4)	1.15 (29.3)
SS-MH8-FL8-M1000-H2			39.40 (1000.0)	0.41 (10.4)	1.30 (33.1)

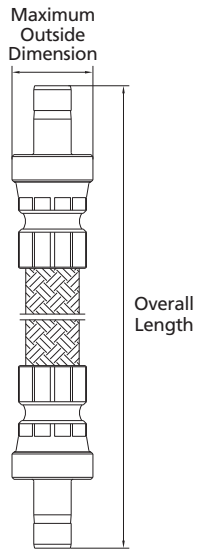

Tube Adapter End

Ordering Number	Nominal Hose Size	Tube Adapter Size	Overall Length	Minimum Inside Diameter	Maximum Outside Dimension
		in.	in. (mm)	in. (mm)	in. (mm)
SS-MH4-FT4-F24-H2	1/4	1/4	24.00 (610.0)	0.17 (4.3)	0.81 (20.6)
SS-MM4-FT4-F36-R-H2			36.00 (914.0)	0.17 (4.3)	0.76 (19.2)
SS-MH4-FT4-M1000-H2			39.40 (1000.0)	0.17 (4.3)	0.81 (20.6)
SS-MH6-FT6-F24-H2	3/8	3/8	24.00 (610.0)	0.27 (6.8)	1.01 (25.6)
SS-MM6-FT6-F36-R-H2			36.00 (914.0)	0.27 (6.8)	0.91 (23.1)
SS-MM6-FT6-M1000-R-H2			39.40 (1000.0)	0.27 (6.8)	0.91 (23.1)
SS-MH8-FT8-F24-H2	1/2	1/2	24.00 (610.0)	0.37 (9.4)	1.14 (29.0)
SS-MM8-FT8-F36-R-H2			36.00 (914.0)	0.37 (9.4)	1.02 (26.0)
SS-MH8-FT8-M1000-H2			39.40 (1000.0)	0.37 (9.4)	1.14 (29.0)

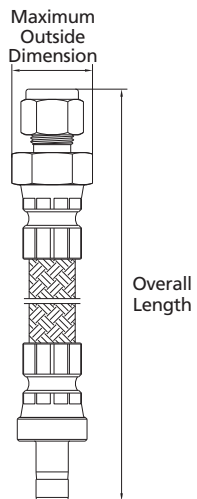

Tube Fitting to Tube Adapter End

Ordering Number	Nominal Hose Size	Tube Fitting Size	Overall Length	Minimum Inside Diameter	Maximum Outside Dimension
		in.	in. (mm)	in. (mm)	in. (mm)
SS-MH4-FL4-FT4-F24-H2	1/4	1/4	24.00 (610.0)	0.17 (4.3)	0.94 (23.8)
SS-MM4-FL4-FT4-F36-R-H2			36.00 (914.0)	0.37 (9.4)	1.30 (33.1)
SS-MH8-FL8-FT8-M1000-H2	1/2	1/2	39.40 (1000.0)	0.17 (4.3)	0.87 (22.0)
SS-MM8-FL8-FT8-M1000-R-H2			39.40 (1000.0)	0.37 (9.4)	1.15 (29.3)

Tubing



TMP Series Tubing

Features

- FITOK's enhanced-316/316L stainless steel is used for better hydrogen embrittlement resistance and complies with GB50516-2021 Technical Code for Hydrogen Fuelling Station, in which Ni is not less than 12% and Nieq is not less than 28.5%. standard 316/316L and 316Ti stainless steel available upon request
- Tighter dimensional tolerances and lower hardness of enhanced-316/316L, provide better performance for bending and ferrule type connections
- Complies with ASTM A269/ASTM A213
- Working temperature: -325 to 1000 °F (-198 to 537 °C)
- Standard lengths: 10 ft, 20 ft, 3 m, 6 m; customized lengths are also available

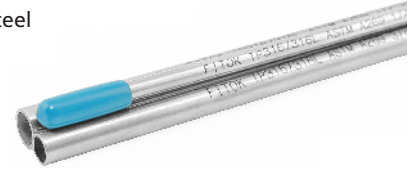

Materials

UNS	Grade	FITOK Designator	Composition %				
			C	Cr	Ni	Mo	Ti
Enhanced-S31600/S31603	Enhanced-316/316L ^②	SH	≤0.030	17-18	12-14	2.6-3.0	—
S31600/S31603	316/316L	SS	≤0.035 ^①	16-18	10-14	2.0-3.0	—
S31635	316Ti	6T	0.08	16.5-18	10.5-13.5	2.0-2.5	5X (C+N)-0.70

① The allowable carbon content of tubing with outside diameter smaller than 1/2" or wall thickness smaller than 0.049" is up to 0.04%.

② Nieq formula: Nieq=Ni+12.6C+1.05Mn+0.65Cr+0.98Mo+0.35Si.

Mechanical Properties

UNS	Grade	Yield Strength ksi (MPa)	Tensile Strength ksi (MPa)	Elongation %	Hardness
Enhanced-S31600/S31603	Enhanced-316/316L	≥30 (205)	≥75 (515)	≥35	≤78 HRB
S31600/S31603	316/316L				≤80 HRB
S31635	316Ti				

Dimensional Tolerance

Tube O.D. (D) in. (mm)	Enhanced-316/316L		316/316L/316Ti	
	O.D. Tolerance in. (mm)	Wall Thickness Tolerance %	O.D. Tolerance in. (mm)	Wall Thickness Tolerance %
3/32 (2.38) ≤ D < 3/16 (4.76)	+0.002 (0.05)/-0	+/-10	+0.003 (0.08)/-0	+/-10
3/16 (4.76) ≤ D ≤ 1 (25.4)	+/-0.003 (0.08)		+/-0.004 (0.10)	

Ordering Information

Ordering Number ^①		Tube O.D.	Wall Thickness	Working Pressure ^② psig (bar)
SH-TMP-4-035-20-BA	SH-TMP-4-035-6M-BA	1/4"	0.035"	5100 (350)
SH-TMP-4-049-20-BA	SH-TMP-4-049-6M-BA	1/4"	0.049"	7500 (517)
SH-TMP-5-049-20-BA	SH-TMP-5-049-6M-BA	5/16"	0.049"	5800 (400)
SH-TMP-6-065-20-BA	SH-TMP-6-065-6M-BA	3/8"	0.065"	6500 (448)
SH-TMP-8-065-20-BA	SH-TMP-8-065-6M-BA	1/2"	0.065"	5100 (352)
SH-TMP-8-083-20-BA	SH-TMP-8-083-6M-BA	1/2"	0.083"	6700 (462)
SH-TMP-10-083-20-BA	SH-TMP-10-083-6M-BA	5/8"	0.083"	5200 (359)
—	SH-TMP-6M-1.0-6M-BA	6 mm	1.0 mm	6090 (420)
—	SH-TMP-8M-1.2-6M-BA	8 mm	1.2 mm	5655 (390)
—	SH-TMP-8M-1.5-6M-BA	8 mm	1.5 mm	7540 (520)
—	SH-TMP-10M-1.5-6M-BA	10 mm	1.5 mm	5800 (400)
—	SH-TMP-12M-2.0-6M-BA	12 mm	2.0 mm	6815 (470)
—	SH-TMP-14M-2.0-6M-BA	14 mm	2.0 mm	5510 (380)
—	SH-TMP-15M-2.0-6M-BA	15 mm	2.0 mm	5220 (360)
—	SH-TMP-16M-2.5-6M-BA	16 mm	2.5 mm	5800 (400)

① BA means Bright Annealed.

② Working pressures are calculated from an S value of 20000 psig (138 MPa) for ASTM A269 tubing at -20 to 100 °F (-28 to 38 °C) for ASME B31.3.

TCT Series Tubing

Features

- FITOK's enhanced-316/316L stainless steel is used for better hydrogen embrittlement resistance and complies with GB50516-2021 Technical Code for Hydrogen Fuelling Station, in which Ni is not less than 12% and Nieq is not less than 28.5%. standard 316/316L and 316Ti stainless steel available upon request
- Tighter dimensional tolerances and lower hardness of enhanced-316/316L, provide better performance for bending and ferrule type connections
- Complies with ASTM A269
- Working temperature: -325 to 1000 °F (-198 to 537 °C)



Materials

UNS	Grade	FITOK Designator	Composition %			
			C	Cr	Ni	Mo
Enhanced-S31600/S31603	Enhanced-316/316L ^②	SH	≤0.030	17-18	12-14	2.6-3.0
S31600/S31603	316/316L	SS	≤0.035 ^①	16-18	10-14	2.0-3.0

① The allowable carbon content of tubing with outside diameter smaller than 1/2" or wall thickness smaller than 0.049" is up to 0.04%.

② Nieq formula: Nieq=Ni+12.6C+1.05Mn+0.65Cr+0.98Mo+0.35Si.

Mechanical Properties

UNS	Grade	Yield Strength ksi (MPa)	Tensile Strength ksi (MPa)	Elongation %	Hardness
Enhanced-S31600/S31603	Enhanced-316/316L	≥30 (205)	≥75 (515)	≥35	≤78 HRB
S31600/S31603	316/316L				≤80 HRB

Dimensional Tolerance

Tube O.D. (D) in. (mm)	Enhanced-316/316L		316/316L	
	O.D. Tolerance in. (mm)	Wall Thickness Tolerance %	O.D. Tolerance in. (mm)	Wall Thickness Tolerance %
$3/32 (2.38) \leq D < 3/16 (4.76)$	+0.002 (0.05)/-0	+/-10	+0.003 (0.08)/-0	+/-10
$3/16 (4.76) \leq D \leq 1 (25.4)$	+/-0.003 (0.08)		+/-0.004 (0.10)	

Ordering Information

Ordering Number ^①		Tube O.D.	Wall Thickness	Working Pressure ^② psig (bar)	Standard Coil Length M (FT)
SH-TCT-4-035-FT-BA	SH-TCT-4-035-M-BA	1/4"	0.035"	5100 (350)	183 (600)
SH-TCT-4-049-FT-BA	SH-TCT-4-049-M-BA	1/4"	0.049"	7500 (517)	122 (400)
SH-TCT-6-065-FT-BA	SH-TCT-6-065-M-BA	3/8"	0.065"	6500 (448)	92 (300)
SH-TCT-8-065-FT-BA	SH-TCT-8-065-M-BA	1/2"	0.065"	5100 (352)	67 (220)
SH-TCT-8-083-FT-BA	SH-TCT-8-083-M-BA	1/2"	0.083"	6700 (462)	67 (220)
—	SH-TCT-6M-1.0-M-BA	6 mm	1.0 mm	6090 (420)	120 (—)
—	SH-TCT-8M-1.2-M-BA	8 mm	1.2 mm	5655 (390)	120 (—)
—	SH-TCT-8M-1.5-M-BA	8 mm	1.5 mm	7540 (520)	120 (—)
—	SH-TCT-10M-1.5-M-BA	10 mm	1.5 mm	5800 (400)	100 (—)
—	SH-TCT-12M-2.0-M-BA	12 mm	2.0 mm	6815 (470)	60 (—)

① BA means Bright Annealed.

② Working pressures are calculated from an S value of 20000 psig (138 MPa) for ASTM A269 tubing at -20 to 100 °F (-28 to 38 °C) for ASME B31.3.

T15 Series Tubing

Features

- ⦿ FITOK's enhanced-316/316L stainless steel is used for better hydrogen embrittlement resistance and complies with GB50516-2021 Technical Code for Hydrogen Fuelling Station, in which Ni is not less than 12% and Nieq is not less than 28.5%. standard 316/316L and 316Ti stainless steel available upon request
- ⦿ Heavy-wall annealed seamless tubing complies with ASTM A269
- ⦿ Working temperature: -325 to 800 °F (-198 to 427 °C)
- ⦿ T15 series can be used with any ferrule type tube fittings.
The best match is with FITOK 20D series tube fittings
- ⦿ Standard lengths: 10 ft, 20 ft, 3 m, 6 m; customized lengths are also available

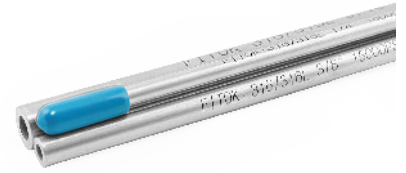

Materials

UNS	Grade	FITOK Designator	Composition %							
			C	Mn	P	S	Si	Cr	Ni	Mo
Enhanced-S31600/S31603	Enhanced-316/316L ^①	SH	≤0.030	≤2.00	≤0.045	≤0.03	≤1.00	17-18	12-14	2.6-3.0
S31600/S31603	316/316L	SS	≤0.035					16-18	10-14	2.0-3.0

① Nieq formula: Nieq=Ni+12.6C+1.05Mn+0.65Cr+0.98Mo+0.35Si.

Mechanical Properties

UNS	Grade	Yield Strength ksi (MPa)	Tensile Strength ksi (MPa)	Elongation %	Hardness
Enhanced-S31600/S31603	Enhanced-316/316L	≥30 (205)	≥75 (515)	≥30	≤90 HRB
S31600/S31603	316/316L				

Dimensional Tolerance

Tube O.D. in.	Enhanced-316/316L		316/316L	
	O.D. Tolerance in. (mm)	Wall Thickness Tolerance %	O.D. Tolerance in. (mm)	Wall Thickness Tolerance %
1/8	+0.002 (0.05)/-0	+/-10	+/-0.003 (0.08)	+/-10
1/4	+/-0.004 (0.10)		+/-0.005 (0.13)	
3/8				
1/2				

Ordering Information

Ordering Number		Tube O.D. in.	Wall Thickness in.	Working Pressure ^① psig (bar)
SH-T15-A-2-037-20	SH-T15-A-2-037-6M	1/8	0.037	15000 (1034)
SH-T15-A-4-083-20	SH-T15-A-4-083-6M	1/4	0.083	
SH-T15-A-6-118-20	SH-T15-A-6-118-6M	3/8	0.118	
SH-T15-A-8-156-20	SH-T15-A-8-156-6M	1/2	0.156	

① Working pressures are calculated from an S value of 20000 psig (138 MPa) for ASTM A269 tubing at -20 to 100 °F (-28 to 38 °C) for ASME B31.3.

T20D Series Tubing

Features

- FITOK's enhanced-316/316L stainless steel is used for better hydrogen embrittlement resistance and complies with GB50516-2021 Technical Code for Hydrogen Fuelling Station, in which Ni is not less than 12% and Nieq is not less than 28.5%. standard 316/316L and 316Ti stainless steel available upon request
- Cold-drawn 1/8-hard seamless tubing, chemical compositions comply with ASTM A269, and holds tighter dimensional tolerances for hydrogen applications
- Working temperature: -325 to 800 °F (-198 to 427 °C)
- For use with any medium pressure ferrule type tube fittings.
The best match is with FITOK 20D series tube fittings
- Standard lengths: 10 ft, 20 ft, 3 m, 6 m, customized lengths are also available

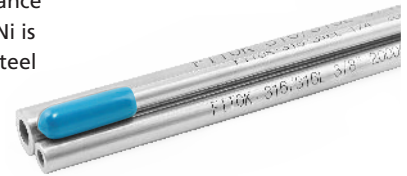

Materials

UNS	Grade	FITOK Designator	Composition %							
			C	Mn	P	S	Si	Cr	Ni	Mo
Enhanced-S31600/S31603	Enhanced-316/316L ^①	SH	≤0.030	≤2.00	≤0.045	≤0.03	≤1.00	17-18	12-14	2.6-3.0
S31600/S31603	316/316L	SS	≤0.035					16-18	10-14	2.0-3.0

① Nieq formula: Nieq=Ni+12.6C+1.05Mn+0.65Cr+0.98Mo+0.35Si.

Mechanical Properties

UNS	Grade	Yield Strength ksi (MPa)	Tensile Strength ksi (MPa)	Elongation %	Hardness
Enhanced-S31600/S31603	Enhanced-316/316L	87-110 (600-758)	105-140 (724-965)	≥25	≤26 HRC
S31600/S31603	316/316L				

Dimensional Tolerance

Tube O.D. in.	Enhanced-316/316L		316/316L	
	O.D. Tolerance in. (mm)	Wall Thickness Tolerance %	O.D. Tolerance in. (mm)	Wall Thickness Tolerance %
1/4	+/-0.004 (0.10)	+/-10	+/-0.005 (0.13)	+/-10
3/8				
1/2				

Ordering Information

Ordering Number		Tube O.D. in.	Wall Thickness in.	Working Pressure ^① psig (bar)
SH-T20D-4-065-20	SH-T20D-4-065-6M	1/4	0.065	20000 (1379)
SH-T20D-6-083-20	SH-T20D-6-083-6M	3/8	0.083	
SH-T20D-8-109-20	SH-T20D-8-109-6M	1/2	0.109	

① Working pressures are calculated from an S value of 50000 psig (344 MPa) at -20 to 100 °F (-28 to 38 °C) for ASME B31.3 Chapter IX High Pressure Piping.

T20M Series Tubing

Features

- FITOK's enhanced-316/316L stainless steel is used for better hydrogen embrittlement resistance, and complies with GB50516-2021 Technical Code for Hydrogen Fuelling Station, in which Ni is not less than 12% and Nieq is not less than 28.5%. standard 316/316L and 316Ti stainless steel available upon request
- Cold-drawn seamless tubing, chemical compositions comply with ASTM A269
- Working temperature: -423 to 1200 °F (-252 to 649 °C)
- For use with any cone and thread type medium pressure fittings.
The best match is with FITOK 20M series medium pressure fittings
- Standard lengths: 10 ft, 20 ft, 3 m, 6 m, customized lengths are also available

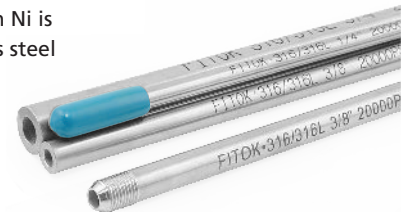

Materials

UNS	Grade	FITOK Designator	Composition %							
			C	Mn	P	S	Si	Cr	Ni	Mo
Enhanced-S31600/S31603	Enhanced-316/316L ^①	SH	≤0.030	≤2.00	≤0.045	≤0.03	≤1.00	17-18	12-14	2.6-3.0
S31600/S31603	316/316L	SS	≤0.035					16-18	10-14	2.0-3.0

① Nieq formula: Nieq=Ni+12.6C+1.05Mn+0.65Cr+0.98Mo+0.35Si.

Dimensional Tolerance

Tube O.D. in.	O.D. Tolerance in. (mm)	Tube I.D. in.	I.D. Tolerance in. (mm)
1/4	-0.002 (0.05)/-0.007 (0.18)	0.109	0/-0.005 (0.13)
3/8	-0.005 (0.13)/-0.01 (0.26)	0.203	
9/16		0.312	

Ordering Information

Ordering Number		Tube O.D. in.	Tube I.D. in.	Working Pressure ^① psig (bar)
SH-T20M-4-20	SH-T20M-4-6M	1/4	0.109	20000 (1379)
SH-T20M-6-20	SH-T20M-6-6M	3/8	0.203	
SH-T20M-9-20	SH-T20M-9-6M	9/16	0.312	

① Working pressures are calculated from an S value of 50000 psig (344 MPa) at -20 to 100 °F (-28 to 38 °C) for ASME B31.3 Chapter IX High Pressure Piping.

Coned and Threaded Nipples



Ordering Number	Tube O.D. in.	Tube I.D. in.	Length L ^① in. (mm)
SH-T20M-4CT-3	1/4	0.109	3.00 (76.2)
SH-T20M-4CT-6	1/4	0.109	6.00 (152.4)
SH-T20M-4CT-12	1/4	0.109	12.00 (304.8)
SH-T20M-6CT-3	3/8	0.203	3.00 (76.2)
SH-T20M-6CT-6	3/8	0.203	6.00 (152.4)
SH-T20M-6CT-12	3/8	0.203	12.00 (304.8)
SH-T20M-9CT-4	9/16	0.312	4.00 (101.6)
SH-T20M-9CT-8	9/16	0.312	8.00 (203.2)
SH-T20M-9CT-12	9/16	0.312	12.00 (304.8)

① Nipples in customized length available upon request.

Other Related Products



Face Seal Fittings



Flow Control Valves



Tools



Sampling Systems



Hydrogen Gas Booster Systems

EC79 Approval & Certificates



Vehicle Technology Division

THE NETHERLANDS
(N E D E R L A N D)



EC TYPE-APPROVAL CERTIFICATE

Communication concerning:

- EC type-approval⁽¹⁾
- extension of EC type-approval⁽¹⁾
- refusal of EC type-approval⁽¹⁾
- withdrawal of EC type-approval⁽¹⁾

} of a type of
hydrogen component

with regard to Regulation (EC) number 79/2009, as implemented by Regulation (EU) number 406/2010.

EC type-approval number : **e4*79/2009*406/2010*0028*00 corr02**

Reason for extension : Reason of correction:
- Typo in manufacturer address has been revised.

SECTION I

0.1. Make (trade name of manufacturer) : FITOK Incorporated

0.2. Type : FITOK 6 Series Tube Fittings

0.3. Means of identification of type, if marked on the component⁽²⁾ : Label attached to the body and number engraved

0.3.1. Location of that marking : Body of the component (see drawing)

0.5. Name and address of manufacturer : FITOK Incorporated
No. 164 Xinqu Village, Tiantou Community
Shijing Street
Pingshan District
Shenzhen 518118
China

0.7. In the case of components and separate technical units, location and method of affixing of the EC approval mark : N.A.



P.O. Box 777 T. + 31 (0)79 545 83 02 *Vehicle Admisson & Surveillance*
2700 AT Zoetermeer E-mail: fito@rdw.nl
The Netherlands www.rdw.nl

Page 1 of 4

FITOK 6D Series Tube Fittings 35 MPa
(Old Name: 6 Series Tube Fittings)



Vehicle Technology Division

THE NETHERLANDS
(N E D E R L A N D)



EC TYPE-APPROVAL CERTIFICATE

Communication concerning:

- EC type-approval⁽¹⁾
- extension of EC type-approval⁽¹⁾
- refusal of EC type-approval⁽¹⁾
- withdrawal of EC type-approval⁽¹⁾

} of a type of
hydrogen component

with regard to Regulation (EC) number 79/2009, as implemented by Regulation (EU) number 406/2010.

EC type-approval number : **e4*79/2009*406/2010*0037*00 corr01**

Reason for extension : Reason of correction:
- Typo in manufacturer address has been revised.

SECTION I

0.1. Make (trade name of manufacturer) : FITOK Incorporated

0.2. Type : FITOK 20D Series Tube Fittings

0.3. Means of identification of type, if marked on the component⁽²⁾ : Label attached to the body and number engraved

0.3.1. Location of that marking : Body of the component (see drawing)

0.5. Name and address of manufacturer : FITOK Incorporated
No. 164 Xinqu Village, Tiantou Community
Shijing Street
Pingshan District
Shenzhen 518118
China

0.7. In the case of components and separate technical units, location and method of affixing of the EC approval mark : N.A.



P.O. Box 777 T. + 31 (0)79 545 83 02 *Vehicle Admisson & Surveillance*
2700 AT Zoetermeer E-mail: fito@rdw.nl
The Netherlands www.rdw.nl

Page 1 of 4

FITOK 20D Series Tube Fittings 70 MPa

www.fitok.com
info@fitok.com



Copyright © 2022 FITOK Group
C-A-AFH-V2210-EN