



Measurement Solutions



About VorTek Instruments

Established in 1995, VorTek Instruments is a leading manufacturer of precision flowmeters for the measurement of liquid, gas, steam, and energy.

Our flow meter technologies include vortex, ultrasonic, turbine, and differential pressure. Our design engineers have over 100 years of combined experience in the flow measurement industry, so we are adept at designing custom-built solutions when a standard product will not work. We serve customers in various industries, including district energy/HVAC, chemical, food & beverage, life sciences, power generation, oil & gas, and water & wastewater.

Our skilled application engineers are available by phone or email to answer questions and provide timely technical assistance. We also maintain a network of knowledgeable representatives across the globe. Our representatives are factory trained and capable of providing on-site product training and support. We are committed to supporting the products we manufacture and the customers we serve.

VorTek Instruments maintains stringent quality standards, performing extensive functional tests, calibrations, and quality checks before every shipment leaves our Longmont, Colorado manufacturing facility. We are ISO 9001:2015 certified for "Design, Manufacture & Service of Industrial Instrumentation Products with emphasis on Flow Measurement Devices."

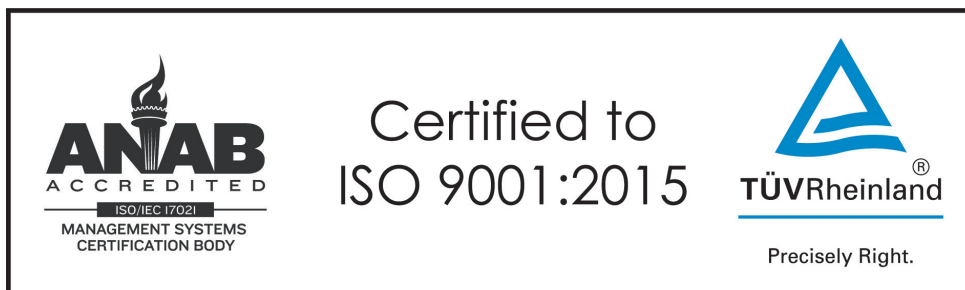

Company History

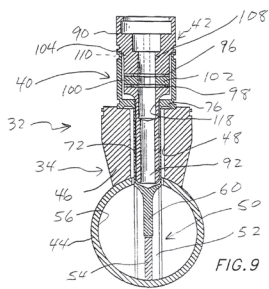
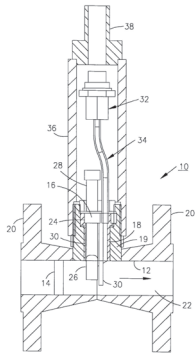
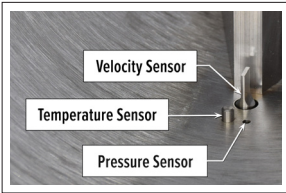

azbil



- 1995** VorTek Instruments is founded.
- 1996** Creation of calibration lab for inline flowmeters up to 3" in size.
- 1997** Creation of the world's first multivariable inline & insertion vortex flowmeters, both with integrated pressure & temperature sensors.
- 1999** Patent issued for "Vortex Flowmeter Including Cantilevered Vortex and Vibration Sensing Beams."
- 2001** Patent issued for "Rocker style sensor system for use in a vortex shedding flowmeter."
- 2005** Introduction of world's first two-wire vortex flowmeter with integrated pressure & temperature sensors.
- 2007** FM approval & certification of all products.
- 2008** Expansion of calibration lab for inline flowmeters up to 8" in size.
- 2008** ATEX/IECEX certification for all products.
- 2012** ISO 9001:2015 Certification.
- 2012** Introduction of TurboPro® Insertion Turbine Flowmeter.
- 2012** VorTek Instruments becomes an Azbil Group company.
- 2016** Expansion of calibration lab for inline flowmeters up to 12" in size.
- 2019** Introduction of VorCone® Steam Quality & Flowmeter.
- 2020** Introduction of SonoPro® Ultrasonic flowmeters.
- 2021** Introduction of the world's first vortex & insertion turbine flowmeters with Power over Ethernet (PoE) capabilities.

Vortex Flowmeters

Vortex flowmeters measure fluid velocity using a principle of operation called the von Kármán effect. It states that when flow passes by an obstruction in the flow path, vortices are generated in a repeating pattern.

In a vortex flowmeter, this obstruction is referred to as a bluff body. The bluff body causes the process fluid to separate and form areas of alternating differential pressure known as vortices around the backside of the bluff body. In Pro-V® vortex flowmeters, a sensitive piezoelectric crystal sensor detects these vortices. The frequency at which the vortices are shed is directly proportional to the fluid velocity. With the fluid velocity and area of the pipe known, a volumetric flow rate can be calculated.

Pro-V vortex flowmeters can provide a compensated mass flow rate by adding optional integrated temperature and pressure sensors. Pro-V flowmeters can also provide a reliable energy measurement (BTU) of water, thermal oils, and steam.

Insertion style vortex flowmeters are a more economical option on large line sizes and can be installed under full process conditions (hot tapping).

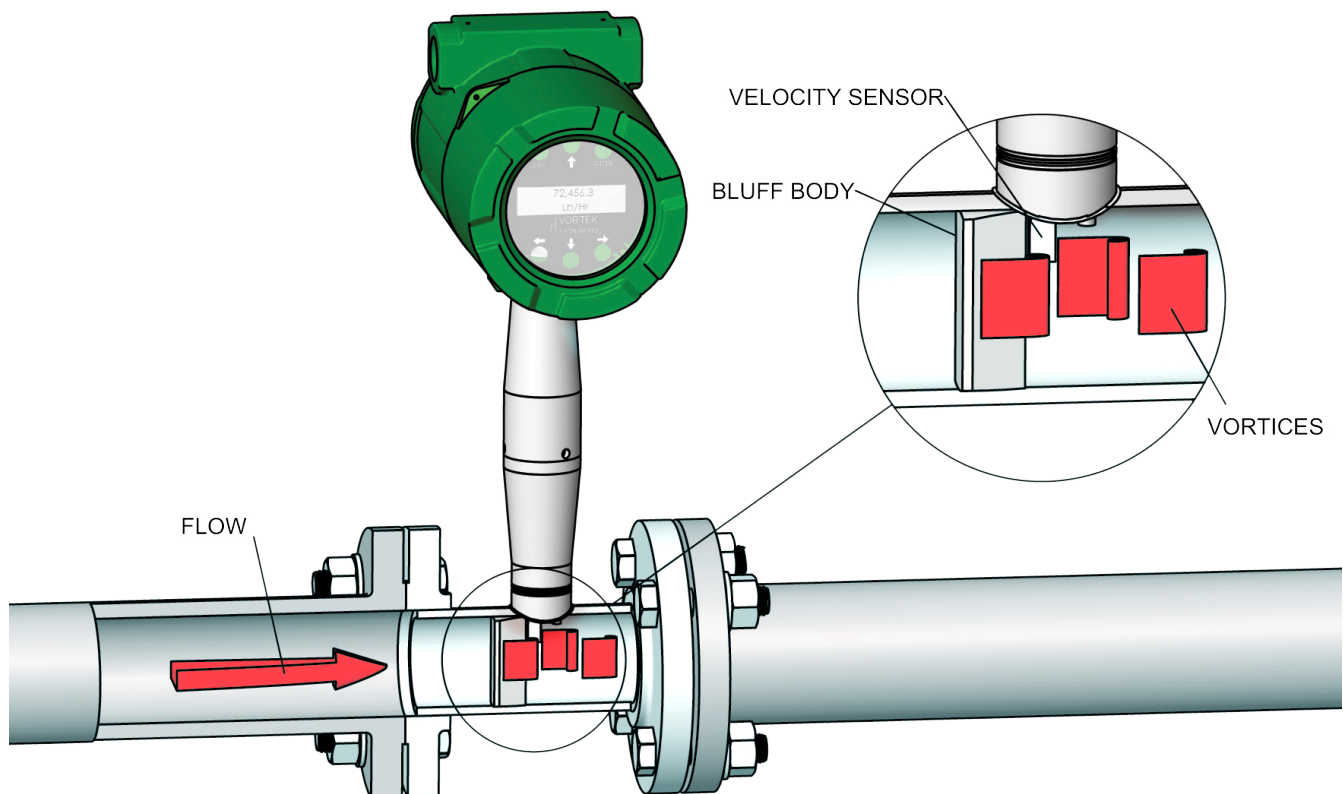

Pro-V® Vortex Flowmeters

- Multivariable Vortex (Integrated Temperature & Pressure Sensors)
- Inline and Insertion models
- Density compensated mass flow measurement
- Advanced communication options such as BACnet™/IP and Modbus® TCP/IP
- Rugged design, no moving parts
- Thermal energy (BTU) metering
- Power over Ethernet (PoE) functionality
- Loop powered models
- Rangeability up to 100:1
- FM, FMC, ATEX, IECEx Approved

Pro-V® Inline Vortex Flowmeter

(Model M22)

KEY FEATURES

- Multivariable design
- Rugged design, no moving parts
- Thermal energy metering (BTU)

COMMON APPLICATIONS

- Saturated & superheated steam
- Density compensated mass flow metering
- Thermal energy metering (BTU)



Pro-V® Inline Vortex Flowmeter

(Model M24)

KEY FEATURES

- Multivariable design
- Reduced bore option for low flows
- Thermal energy metering (BTU)

COMMON APPLICATIONS

- Saturated & superheated steam
- Density compensated mass flow metering
- Low flow rate applications



Pro-V® Insertion Vortex Flowmeter

(Model M23)

KEY FEATURES

- Multivariable design
- Economical option for large line sizes
- Process shutdown not required for installation

COMMON APPLICATIONS

- Saturated & superheated steam
- Density compensated mass flow metering
- Thermal energy metering (BTU)



Transit-Time Ultrasonic Flowmeters

Transit-time ultrasonic flowmeters operate using sound wave signals which travel between a pair of transducers. Both transducers act as transmitters and receivers of these sound wave signals.

Sound waves moving in a fluid carry faster when traveling in the fluid flow direction (downstream) and slower when traveling against the fluid flow (upstream). If there were no fluid flow, the travel times would be identical. The difference in these travel times is measured, and from that, a fluid velocity is calculated. With the area of the pipe and fluid velocity known, the meter calculates a volumetric flow rate. If the fluid density is also known, a mass flow rate can be calculated as well.

SonoPro® ultrasonic flowmeters incorporate high accuracy transit-time ultrasonic technology to deliver accurate

and reliable flow metering. The innovative design incorporates matched precision transducers and signal processing circuitry to accurately measure the flow of most liquids over a wide range of velocities.

SonoPro flowmeters are available with clamp-on or insertion transducers. Clamp-on meters have no wear, create zero pressure loss, and do not require process interruptions to install them since they are attached to the outside of the pipe.

With the addition of external temperature inputs, SonoPro meters can provide a reliable (BTU) energy measurement.

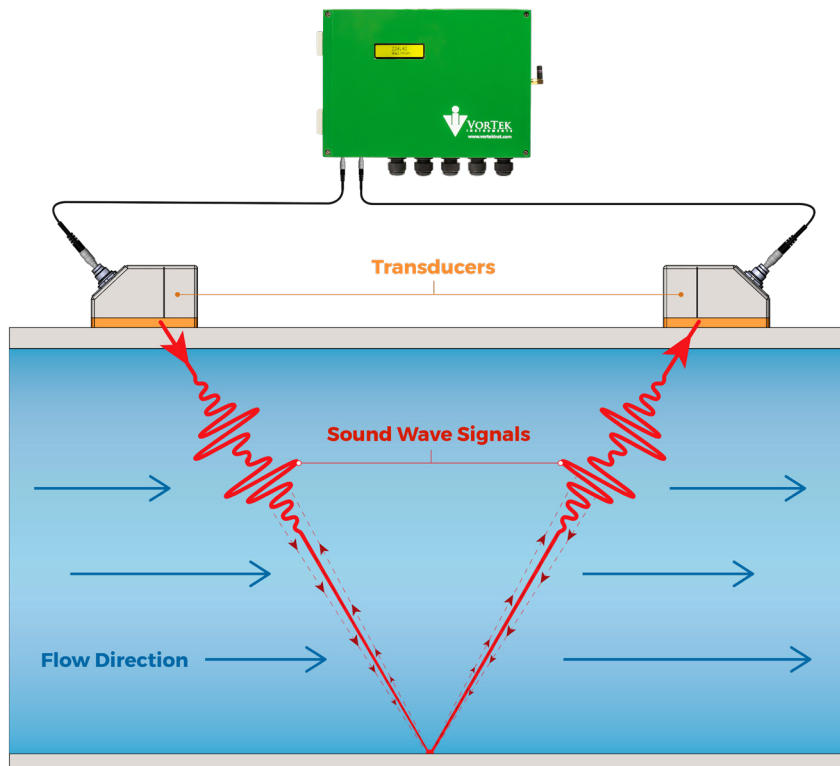

SonoPro[®] Transit-Time Ultrasonic Flowmeters

- No maintenance required
- Non-invasive installation
- No wetted or moving parts
- No pressure drop
- High turndown ratio
- No drifting, no recalibration required
- Bi-directional flow measurement
- Low total cost of ownership

SonoPro[®] Professional Series Flowmeter (Model S36)

KEY FEATURES

- High accuracy flow metering (Up to $\pm 0.75\%$ of reading)
- BACnet[™] IP & ModBus[®] TCP/IP communications
- Compatible with SonoConfig[™] software



COMMON APPLICATIONS

- Glycol metering
- Boiler feedwater
- Chemicals

SonoPro[®] Water Flowmeter (Model U43)

KEY FEATURES

- Non-invasive flow measurement of clean liquids
- Economical flow metering
- Thermal energy metering (BTU)



COMMON APPLICATIONS

- Cost Allocation/ Sub-Metering
- Make-up water
- Potable water

SonoPro[®] Portable Flowmeter (Model U44)

KEY FEATURES

- Portable non-invasive flow measurement of clean liquids
- Internal data logging
- Economical flow metering



COMMON APPLICATIONS

- Spot checking
- Verifying the accuracy of another flowmeter
- Temporary placeholder for fixed mount flowmeter

Ultrasonic Thickness Gauge (Model MT160)

KEY FEATURES

- Non-invasive pipe wall thickness measurements
- No wetted or moving parts

COMMON APPLICATIONS

- Determining pipe thickness



SonoPro[®] Commercial Series Flowmeter (Model U42)

KEY FEATURES

- Non-invasive flow measurement of clean liquids
- Modbus[®] RTU & 4-20mA communications
- Thermal energy metering (BTU)

COMMON APPLICATIONS

- Hot/Chilled water systems
- Condensate return
- Condenser water supply/return



SonoPro[®] Professional Series Portable Flowmeter (Model S34)

KEY FEATURES

- Portable non-invasive flow measurement of clean liquids
- Internal data logging
- Compatible with SonoConfig[™] software

COMMON APPLICATIONS

- Spot checking
- Verifying the accuracy of another flowmeter
- Temporary placeholder for fixed mount flowmeter



SonoConfig[™] Instrument Interface Software

KEY FEATURES

- Setup feature allows for easy transducer installation
- Diagnostic feature makes troubleshooting easy
- Chart logged data in easy-to-understand graphs

COMMON APPLICATIONS

- Communicate with SonoPro[®] flowmeters (Models S34 & S36) providing setup, diagnostic, and data logging tools.



Turbine Flowmeters

Turbine flowmeters measure liquid, gas, and steam flows by detecting the rotational velocity of a turbine rotor in the flow stream.

The rotational velocity of the turbine rotor is directly proportional to the fluid velocity flowing through the turbine. In TurboPro® turbine flowmeters, the turbine blade movement is detected magnetically, with each blade generating a pulse measured by an electrical pickup. This local fluid velocity is used along with other parameters such as pipe size and Reynolds Number to calculate the average fluid velocity in the pipe. With the average fluid velocity and area of the pipe known, a volumetric flow rate is calculated.

TurboPro turbine flowmeters can provide a compensated mass flow rate by adding optional integrated temperature and pressure sensors. TurboPro flowmeters can also provide a reliable energy measurement (BTU) of water, thermal oils, and steam.

Insertion style turbine flowmeters are a more economical option on large line sizes and can be installed under full process conditions (hot tapping).

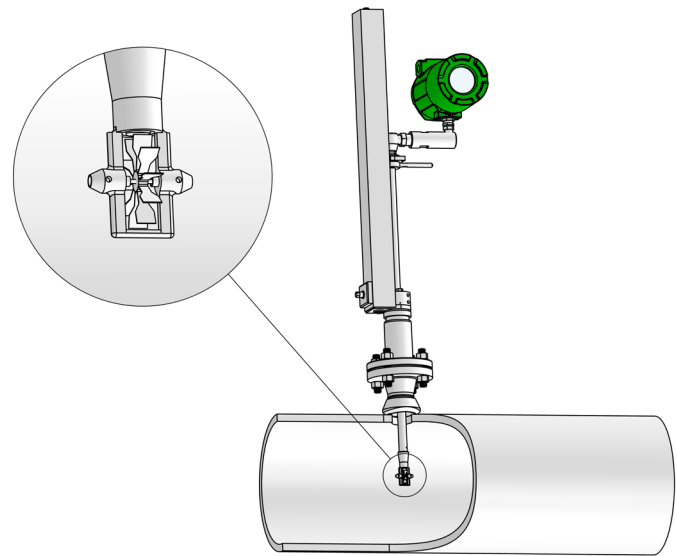

TurboPro® Turbine Flowmeters

- Multivariable design
- Low flow metering
- Minimal pressure drop
- Economical option for large line sizes
- Process shutdown not required for installation

TurboPro® Insertion Turbine Flow Meter (Model Pro-T®)

KEY FEATURES

- Expanded low-flow measuring range
- Economical option for large line sizes
- Process shutdown not required for installation

COMMON APPLICATIONS

- Saturated & superheated steam
- Low flow rate applications
- Thermal energy metering (BTU)



VorCone[®] Steam Quality & Flow Meter

VorCone flowmeters utilize two different flowmeter technologies in combination; vortex and differential pressure.

The design has blended the two separate flow metering principles into one hybrid system where the two meters complement each other's performance. This combination allows for the prediction of the fluid density, volumetric flow rate, and mass flow rate without any fluid density information being required from an external source.

This ability to measure fluid density allows the meter to provide several valuable outputs. In saturated steam service, the meter produces a reliable steam quality (dryness) measurement and mass flow rate reading. In gas service, the meter can calculate the density of changing gas mixtures. For example, natural gas is typically composed of many different gases that vary over time and by application. In wet natural gas service, the meter can provide a reliable liquid loading measurement and gas mass flow rate reading. These are a few examples of the unique capabilities of the VorCone meter.

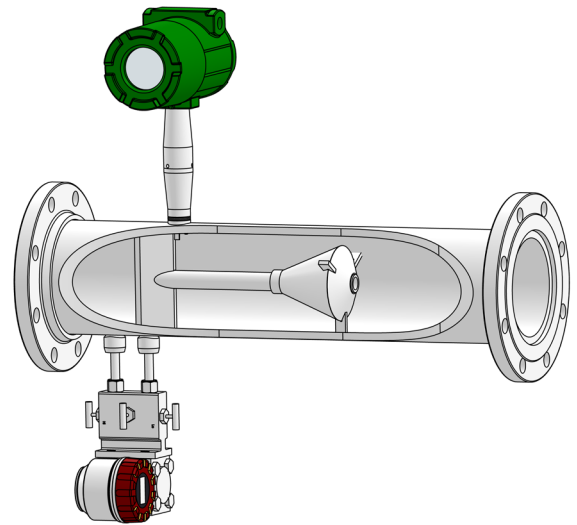

VorCone[®] Flowmeters

- Measures fluid density, volumetric flow rate and mass flow rate without any density information being required from an external source.
- Able to calculate the density of changing gas mixtures.
- In saturated steam service, provides a reliable steam quality (dryness) measurement and steam total mass flow rate reading (steam & water mixture).
- In wet gas service, provides a reliable liquid loading measurement and gas mass flow rate reading.

VorCone[®] Steam Quality & Flow Meter

(Model MVC)

KEY FEATURES

- Wet steam metering & steam quality measurement
- Wet gas metering & liquid loading measurement
- Measures fluid density, volumetric flow & mass flow rate

COMMON APPLICATIONS

- Saturated steam quality metering
- Gas mixtures with a changing composition
- Wet gas flow metering

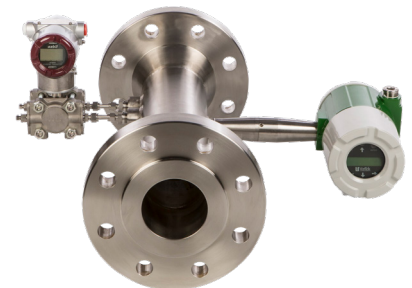

Thermal Energy Metering (BTU)

Thermal energy meters, or BTU meters, measure the energy of hydronic or steam-based heating and cooling systems.

Thermal energy meters consist of a volumetric flow sensor, temperature sensors, and a flow computer. Volumetric flow rate and temperature measurements feed into the flow computer, where the necessary calculations are performed to produce a thermal energy measurement.

Metering thermal energy in this fashion continues to grow in importance, with environmental regulations and financial incentives being the primary drivers. District energy systems and commercial facilities such as universities, hospitals, and airports are adopting thermal energy metering to optimize the performance of their HVAC systems. These modern systems are complex, consisting of chilled and hot water systems, boilers, cooling towers, pumps, and metering equipment. Optimizing these systems is well worth the investment. Increasing energy efficiencies of the heating and cooling infrastructure leads to more environmentally friendly facilities and significant cost savings.

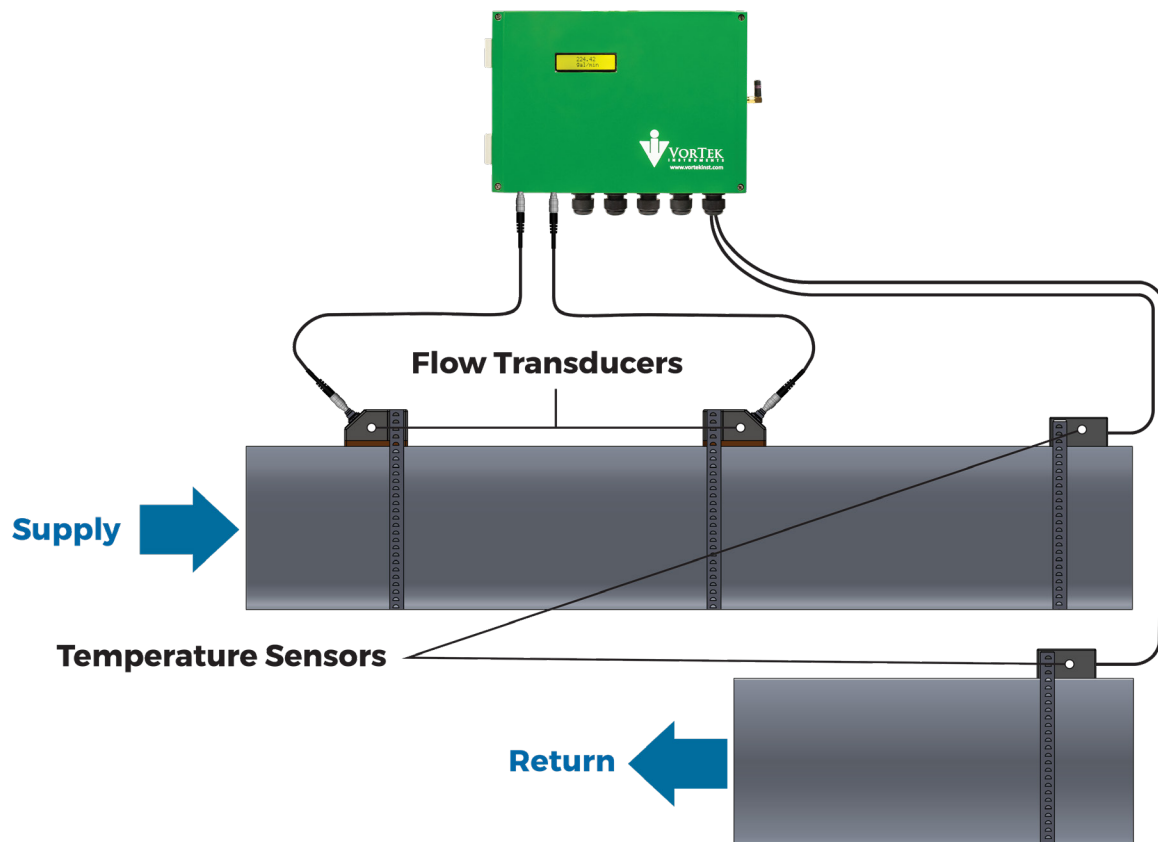

✓ All VorTek flow metering products have thermal energy metering capabilities.



Services Offered

Factory Flowmeter Calibration Services

We offer flowmeter calibration services for a variety of flowmeter technologies, not just our own. Our calibration methods are NIST (National Institute of Standards and Technology) traceable. We meet ASME/ANSI MFC-9M-1988 for "Measurement of liquid flow in closed conduits by weighing method." Each flowmeter calibration includes a signed and dated calibration data sheet with all relevant calibration data.

VorTek Product Training

We offer factory, on-site, and virtual product training options to help our customers understand and utilize the full value of our products.



On-Site Startup, Commissioning, and Troubleshooting Services

We offer on-site support serving a variety of customer needs. Specific service arrangements will depend upon customer acceptance, insurance, and procedures.

Portable Flowmeter Rental Services

Portable flowmeters are often needed for spot-checking during flow rate surveys, verifying the accuracy of another flowmeter, or even used as a temporary placeholder for fixed mount flowmeters sent out for service or calibration. Our SonoPro® Portable Professional Series Ultrasonic Flow Meters (Model S34) are available to meet your rental needs.

WARRANTY STATEMENT

VorTek Instruments stands by the quality of its products. VorTek Instruments warrants all purchased items to be free from defects in materials and workmanship under normal use and service for a period of 18 months from time of purchase.



ADDITIONAL RESOURCES

Not sure which VorTek flowmeter will work best for your application?

Reference and download our Flowmeter Selection Guide by scanning the QR Code or clicking the link below:

[Flowmeter Selection Guide](#)



Not sure which VorTek flowmeter will meet your communication needs?

Reference and download our Flowmeter Communications Guide by scanning the QR Code or clicking the link below:

[Flowmeter Communications Guide](#)

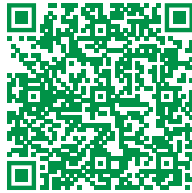

Do you have complete process conditions for your specific flow metering application?

Use our Flowmeter Sizing Program to calculate application-specific flowmeter capabilities and output an application datasheet (PDF) for reference:

[Flowmeter Sizing Program](#)

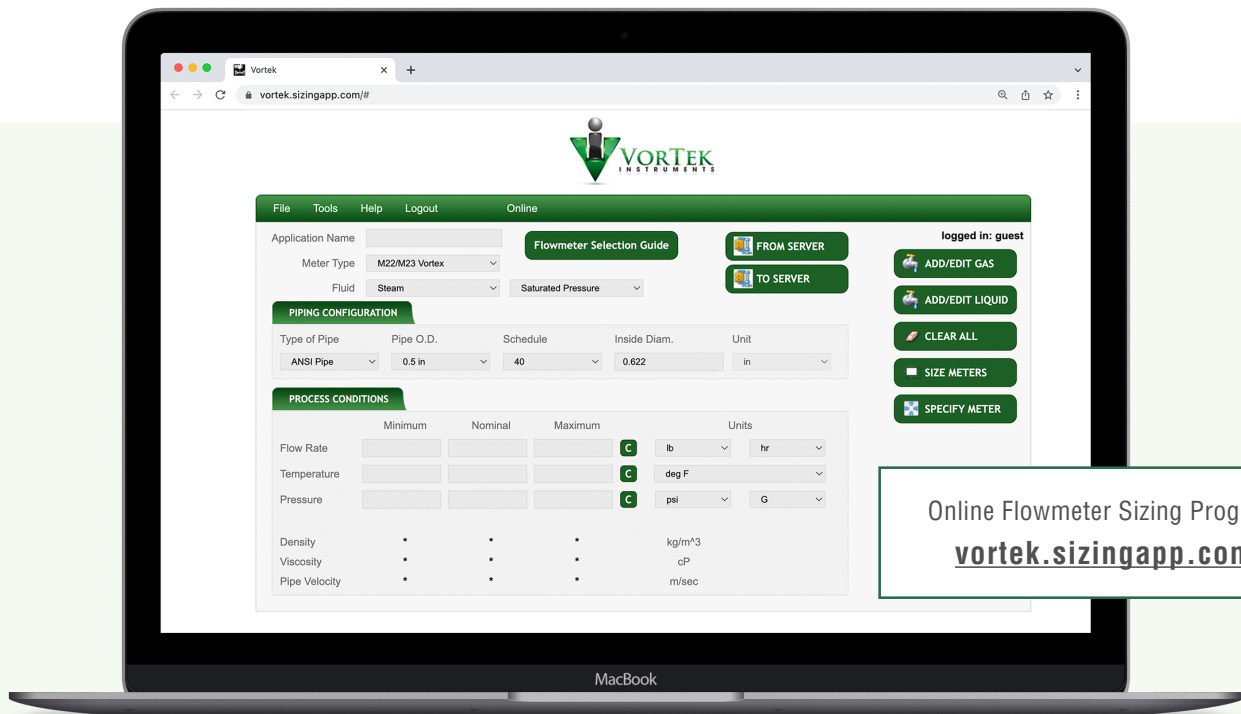
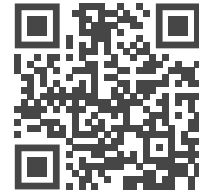

CONTACT US

VORTEK INSTRUMENTS, LLC

📍 8475 West I-25 Frontage Rd.
STE 300 Longmont, CO 80504

☎ (303) 682-9999
✉ info@vortekinst.com



 www.linkedin.com/company/vortek-instruments/

www.vortekinst.com